

# KOTHARI INTERNATIONAL SCHOOL

## Summer Break - Holiday Homework

Session - 2023-24

Cambridge IGCSE-2

### **BUSINESS STUDIES**

#### **Instructions:**

❖ *While answering questions in the assignment, please make sure it is clearly readable.*

❖ *You are already aware of the Business Studies Paper 1 Mark Scheme. Attempt all questions according to the same criteria.*

#### **Week 1 and 2**

1.1 What is meant by 'opportunity cost'? [2]

1.2 What is meant by 'specialization'? [2]

1.3 Identify two advantages of specialization. [2]

1.4 What is meant by 'added value'? [2]

1.5 Explain how a manufacturing business adds value to its products. [4]

1.6 Identify and explain two ways a doctor (tertiary sector business) could increase added value? [4]

1.7 What is meant by the 'primary sector'? [2]

1.8 What is meant by 'primary sector activities'? [2]

1.9 Identify two examples (other than farming) of business activity in the primary sector. [2]

#### **Week 3 and 4**

2.1 Identify and explain two reasons why the size of the public sector might increase overtime. [4]

2.2 What is meant by 'entrepreneur'? [2]

2.3 Identify two characteristics of a successful entrepreneur. [2]

2.4 Identify and explain two ways that a Government could help new businesses to start up. [4]

2.5 Identify and explain two ways that a Government could use to encourage new businesses to start up (other than removing controls on where factories can be built). [6]

**KOTHARI INTERNATIONAL SCHOOL, NOIDA**

**GRADE – IGCSE -2 SUBJECT: BIOLOGY**

**HOLIDAY ASSIGNMENT**

**Q1)** The menstrual cycle involves monthly changes in the ovary and the uterus.

**(a)** Fig. 5.1 shows the sequence of changes within the ovary that occur during the menstrual cycle.

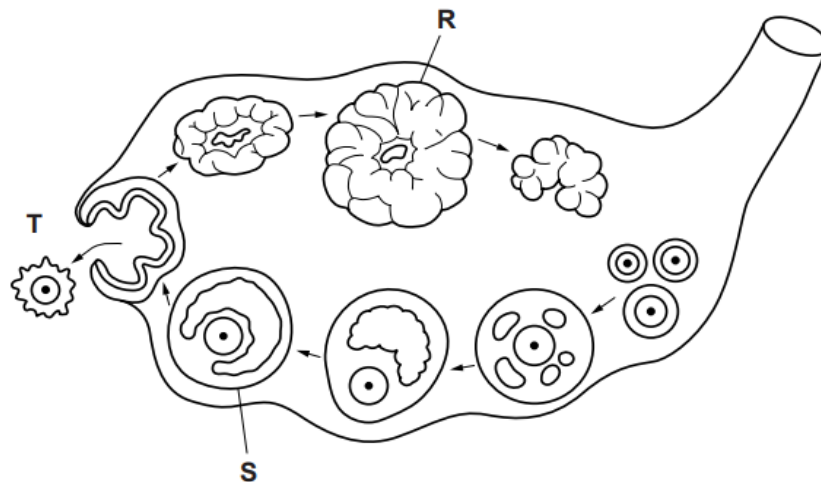

**Fig. 5.1**

- i) Name structures R and S.
- ii) State the name of the process that is occurring at T.

**b)** The ovary secretes hormones that control the growth and maintenance of the lining of the uterus. Name the hormone that stimulates:

- (i) the growth of the lining of the uterus during the first half of the menstrual cycle.
- ii) the maintenance of the lining of the uterus during the second half of the menstrual cycle.

**c)** Fig. 5.2 is an electron micrograph showing a sperm cell on the surface of an egg cell.

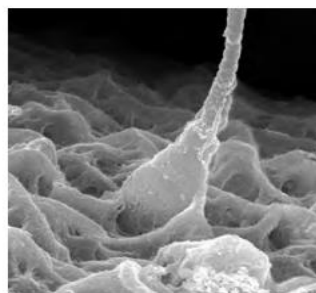

**Fig. 5.2**

- i) State three ways in which a sperm cell differs from an egg cell.

- ii) Human body cells have 46 chromosomes. Human egg and sperm cells have 23 chromosomes each. What term is used to describe the number of chromosomes in a gamete, such as an egg cell or a sperm cell?
- iii) State the organ in which fertilisation occurs in humans.
- iv) Describe what happens between the event shown in Fig. 5.2 and implantation in the uterus.

Q2) Diagrammatically represent cell division processes - mitosis and meiosis.

Q3) During a fast race (a 100-metre sprint), 95% of the energy comes from anaerobic respiration. During a marathon, only 2% of the energy comes from anaerobic respiration.

- (i) State the equation, in symbols, for anaerobic respiration in muscles.
- (ii) Suggest and explain why a sprinter can use mainly anaerobic respiration during the race, while a marathon runner needs to use aerobic respiration.
- (iii) Explain how, during a marathon race, the blood glucose concentration stays fairly constant, but the mass of glycogen in the liver decreases.

Q4) Two brothers have to make a difficult decision. One brother, with blood group AB, has kidney failure and is on dialysis. The healthy brother has agreed to donate one of his kidneys to his brother. He has to have a blood test. Their father has blood group A and their mother has blood group B. The brothers have a sister who has blood group O.

- a) Explain how this girl has blood group O when her parents have different blood groups.

Use the symbols  $I^A$ ,  $I^B$  and  $I^O$  to represent the alleles involved in the inheritance of blood groups.

<i>parental phenotypes</i>	blood group A	×	blood group B
<i>parental genotypes</i>	.....	×	.....
<i>gametes</i>	.....	+	.....
<i>girl's genotype</i>	.....		
<i>girl's phenotype</i>	.....		

b) The healthy brother can only donate the kidney to his brother if they both have the same blood group. What is the probability that the healthy brother also has blood group AB?

Q5) Explain the advantages and disadvantages of self-pollination for flowering plants, such as soybean.

Q6) Four definitions of terms used in genetics are shown in Table 5.1.

**Table 5.1**

<b>definitions</b>	
the outward appearance of an organism	.....
a length of DNA that codes for a protein	.....
having one set of chromosomes	.....
type of nuclear division which gives daughter nuclei that are genetically identical	.....

For each of the definitions, select an appropriate term from the list and write it in the box provided.

- |            |              |           |
|------------|--------------|-----------|
| chromosome | genotype     | mitosis   |
| diploid    | haploid      | mutation  |
| dominant   | heterozygous | phenotype |
| gene       | homozygous   | recessive |

Q7) Plants also respond to stimuli such as light.

- (i) State the name of the response of plants to light. Ahmed was provided with several young plant shoots and a sample of auxin.
- (ii) Describe an experiment he could carry out to show that auxin causes bending of a shoot.
- (iii) Explain the mechanism that results in a shoot bending towards light.
- (iv) Synthetic plant hormones behave in a similar way to auxins. Describe how synthetic plant hormones are effective as weedkillers.

Q8) Explain what is meant by codominance. Represent it through a genetic diagram by taking an example of your choice.

Q9) Vascular bundles, containing xylem and phloem tissue, are situated in the leaf. Describe the structure of xylem tissue.

Q10) Fig. 3.1 shows the human female reproductive system.

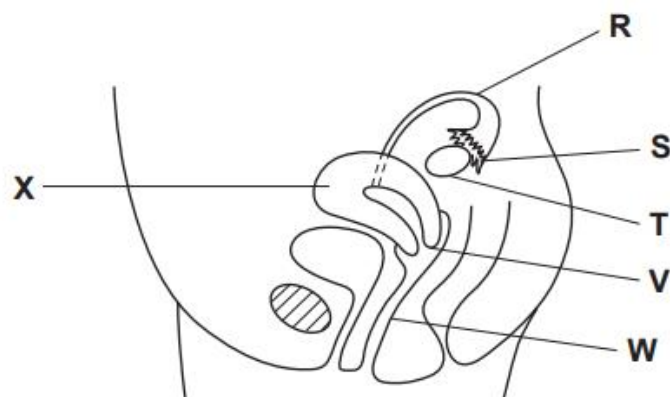

**Fig. 3.1**

(a) Table 3.1 shows four functions of the female reproductive system.

Complete the table by:

- naming the part of the system that carries out each of the functions;
- using the letters from Fig. 3.1 to identify the part of the system named.

One row has been completed for you.

**Table 3.1**

function	name of organ	letter from Fig. 3.1
production of gametes		
site of implantation		
site of fertilisation		
dilates during birth	cervix	<b>V</b>

b) The hormone FSH is important in regulating the menstrual cycle.

State the target organ of FSH and one effect of FSH.

c) The drug clomiphene is given to women who have difficulty in having children. The drug increases the secretion of FSH. As part of treatment for infertility, a woman was given clomiphene for five days. The concentration of oestrogen in her blood was measured every day for 27 days. The results are shown in Fig. 3.2. Describe the changes in oestrogen in the blood over the 27 days. You will gain credit if you use results from Fig. 3.2 in your answer

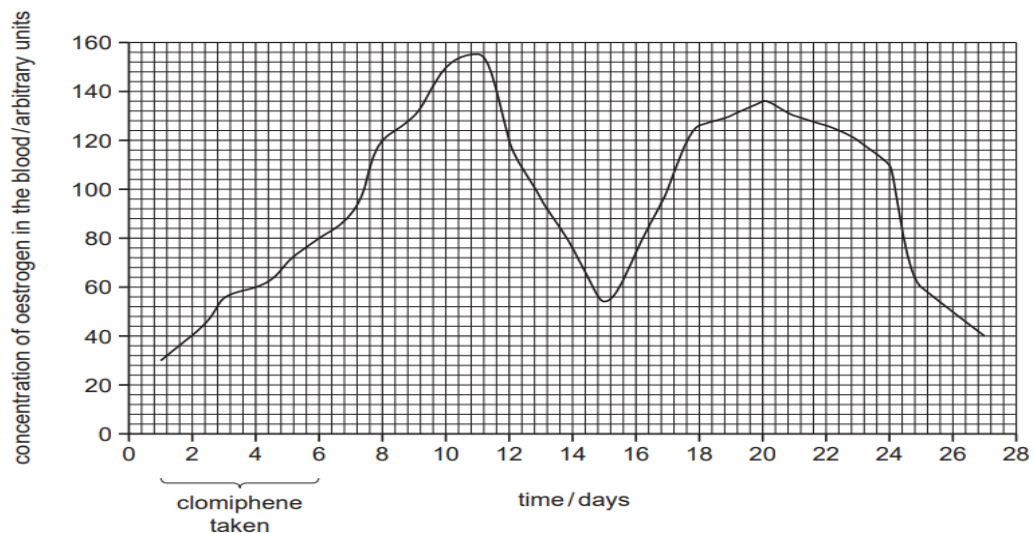

Fig. 3.2

d) Doctors thought that ovulation occurred around day 15. Explain what is meant by the term ovulation.

Q11) Some embryos produced by IVF do not develop because there are problems with their chromosomes, such as having the wrong number. Define the term chromosome. State the correct number of chromosomes that should be in a cell of a human embryo.

Q12) a) Write the balanced chemical reaction for photosynthesis. A student investigated the effect of increasing the concentration of carbon dioxide on the rate of photosynthesis of Cabomba, an aquatic plant. Fig. 4.1 shows the apparatus that the student used.

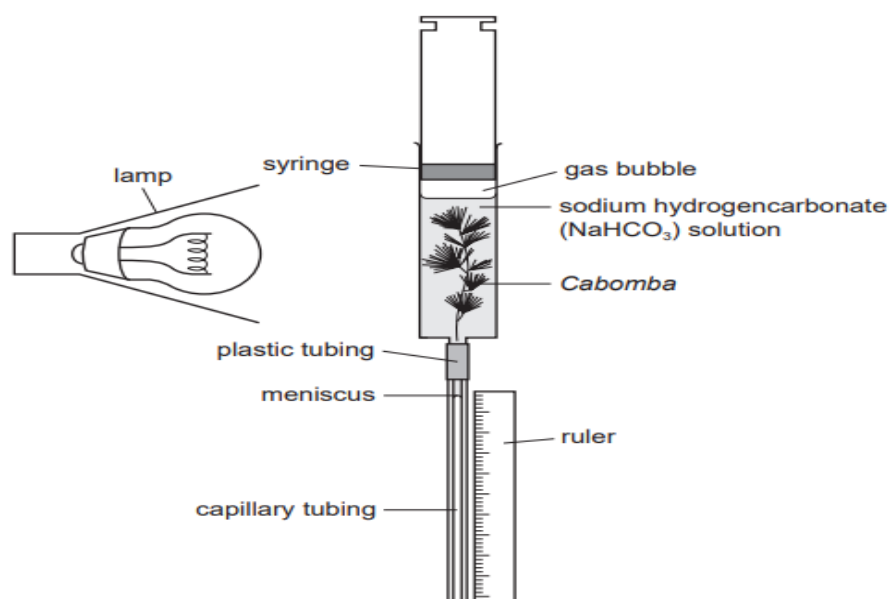

Fig. 4.1

The concentration of carbon dioxide in the water surrounding the plant was changed by adding different concentrations of sodium hydrogen

carbonate solution to the water. The student recorded the time taken for the meniscus to travel 50mm down the tubing. The rate of photosynthesis was calculated as:

$$\text{rate of photosynthesis} = \frac{1000}{t}$$

where  $t$  = time taken in seconds for the meniscus to travel 50 mm.

The student's results are shown in Table 4.1.

**Table 4.1**

concentration of sodium hydrogencarbonate solution / mol per dm <sup>3</sup>	t, time taken for meniscus to travel 50 mm / s	rate of photosynthesis (1000/t)
0.00		
0.01		
0.02		
0.05	350	2.86
0.07	201	
0.10	199	5.03

- b) Calculate the rate of photosynthesis for the concentration of sodium hydrogen carbonate solution of 0.07 mol per dm<sup>3</sup>. Write your answer in the table.
- c) Explain why the lamp must be kept at a fixed distance from the syringe.
- d) Explain what caused the meniscus to move down the capillary tubing.

Q13) Plants that live in water are called hydrophytes. Figure shows a cross-section of a leaf of the hydrophyte, *Nuphar lutea*. The leaves of *N. lutea* float on the surface of water.

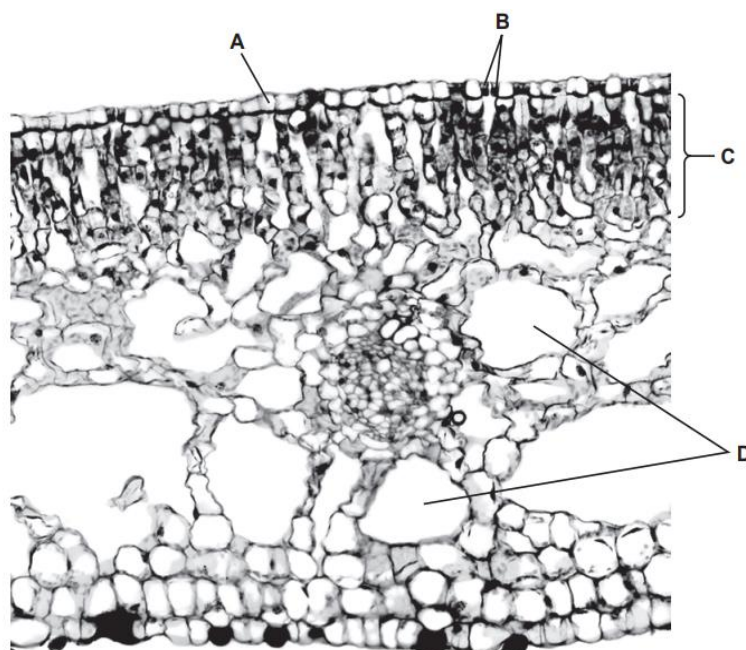

a) Complete Table 5.1 by describing the function of each feature. The function for feature A has already been completed.

Table 5.1

feature	f
A	transparent to allow light to penetrate into the leaf
B	.....
C	.....
D	.....

b) State and explain one way in which the leaves of *N. lutea* are adapted to their environment.

Q14) Fig. 2.1 shows a dialysis machine for treating people who have kidney failure. The dialysate (dialysis fluid) is a solution of glucose and salts.

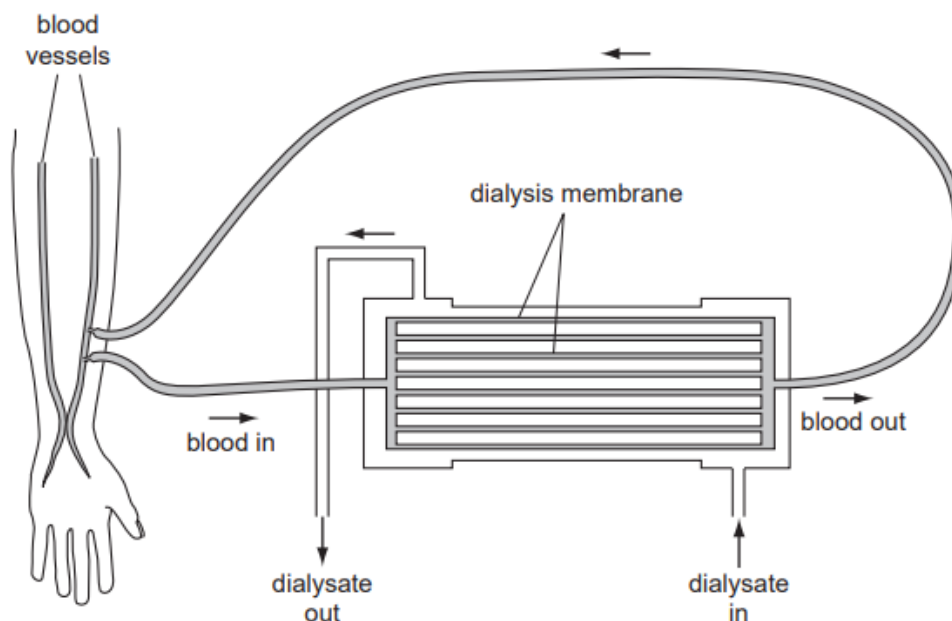

Fig. 2.1

Explain how, when the patient is receiving dialysis treatment

- (i) the loss of plasma proteins and red blood cells is prevented.
- (ii) the normal glucose concentration of the blood is maintained.

Q15) Heparin is added to the blood before it returns to the body from the dialysis machine. Heparin prevents a person's blood from clotting. Describe the process of blood clotting.



**KOTHARI INTERNATIONAL SCHOOL, NOIDA**  
**CAMBRIDGE ASSESSMENT INTERNATIONAL EDUCATION**  
**SESSION 2022-23, IGCSE 2 – MATHEMATICS (0580)**  
**PRACTICE ASSIGNMENT**

1. Showing all your working, solve

(a)  $\frac{5x}{2} - 9 = 0,$

*Answer (a) x = .....*

[2]

(b)  $x^2 + 12x + 3 = 0,$  giving your answers correct to 1 decimal place.

*Answer (b) x = ..... or x = .....*

[4]

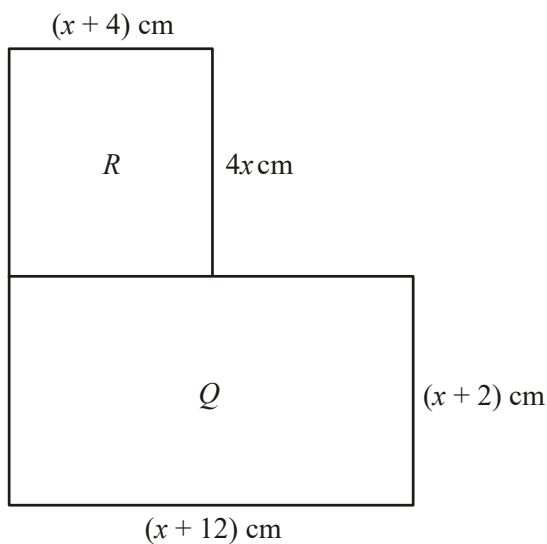

NOT TO SCALE

(a) (i) Write down an expression for the area of rectangle R.

Answer (a) (i) ..... cm<sup>2</sup>

[1]

(ii) Show that the total area of rectangles  $R$  and  $Q$  is  $5x^2 + 30x + 24$  square centimetres.

[1]

(b) The total area of rectangles  $R$  and  $Q$  is  $64 \text{ cm}^2$ .  
Calculate the value of  $x$  correct to 1 decimal place.

Answer (b)  $x =$  .....

[4]

3.

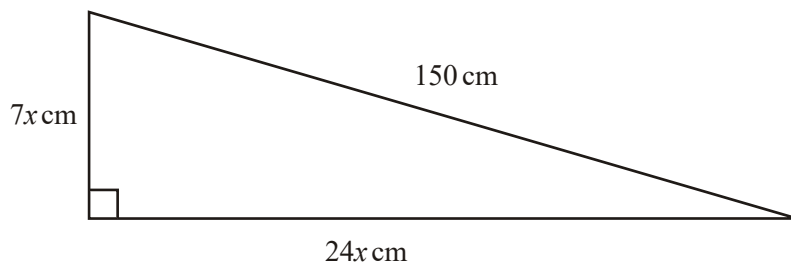

NOT TO SCALE

The right-angled triangle in the diagram has sides of length  $7x \text{ cm}$ ,  $24x \text{ cm}$  and  $150 \text{ cm}$ .

(a) Show that  $x^2 = 36$

[2]

(b) Calculate the perimeter of the triangle.

Answer (b) ..... cm

[1]

4.

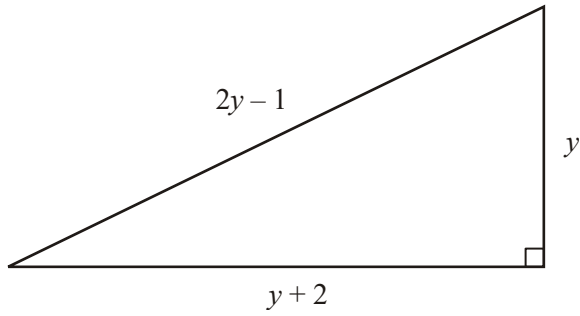

NOT TO SCALE

The diagram shows a right-angled triangle.  
The lengths of the sides are given in terms of  $y$ .

(i) Show that  $2y^2 - 8y - 3 = 0$ .

[3]

(ii) Solve the equation  $2y^2 - 8y - 3 = 0$ , giving your answers to 2 decimal places.

[4]

(iii) Calculate the area of the triangle.

5.

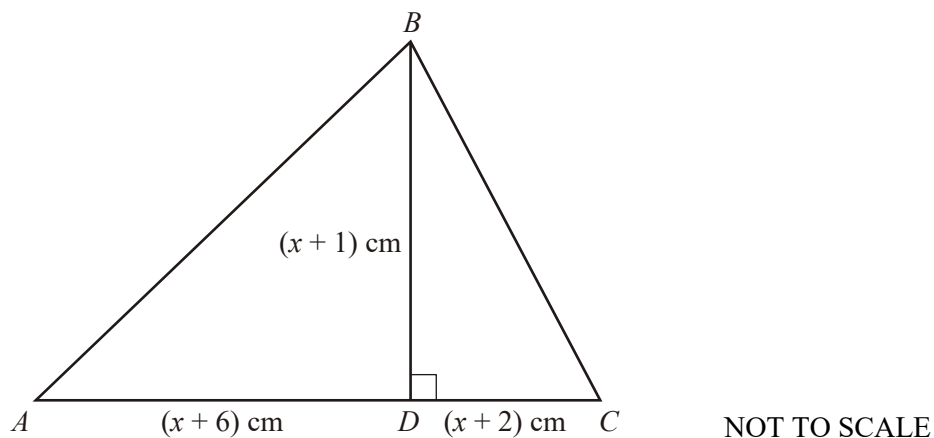

In triangle  $ABC$ , the line  $BD$  is perpendicular to  $AC$ .

$AD = (x + 6)$  cm,  $DC = (x + 2)$  cm and the height  $BD = (x + 1)$  cm.

The area of triangle  $ABC$  is  $40 \text{ cm}^2$ .

(i) Show that  $x^2 + 5x - 36 = 0$ .

*Answer (i)* .....

[3]

(ii) Solve the equation  $x^2 + 5x - 36 = 0$ .

*Answer (ii)*  $x = \dots\dots$  or  $x = \dots\dots$

[2]

(iii) Calculate the length of  $BC$ .

*Answer (iii)*  $BC = \dots\dots\dots$  cm

[2]

6.

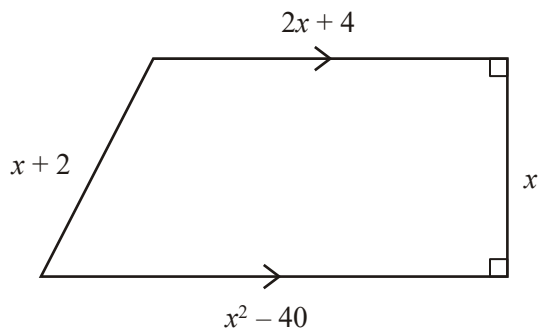

NOT TO SCALE

The diagram shows a trapezium.  
 Two of its angles are  $90^\circ$ .  
 The lengths of the sides are given in terms of  $x$   
 The perimeter is 62 units.

- (i) Write down a quadratic equation in  $x$  to show this information. Simplify your equation.

[2]

- (ii) Solve your quadratic equation.

[2]

- (iii) Write down the only possible value of  $x$ .

[1]

- (iv) Calculate the area of the trapezium.

**KOTHARI INTERNATIONAL SCHOOL, NOIDA**  
**CAMBRIDGE ASSESSMENT INTERNATIONAL EDUCATION**  
**SESSION 2022-23, IGCSE 2 – MATHEMATICS (0580)**  
**PRACTICE ASSIGNMENT**

1. A Helicopter flies from its base B to deliver supplies to two oil rings at C and D. C is 6km due east of B and the distance from C to D is 8km. D is on a bearing of  $120^\circ$  from B.

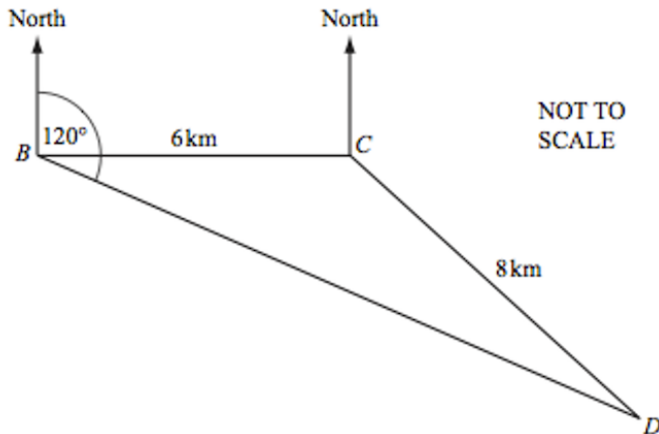

Find the bearing of D from C.

2. Calculate the length of AB.

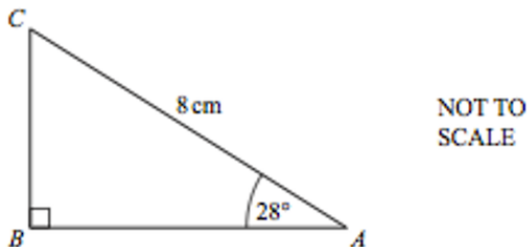

3. The line AB represents the glass walkway between the Petronas Towers in Kuala Lumpur. The walkway is 58.4 metres long and is 170 meters above the ground. The angle of elevation of the point P from A is  $78.3^\circ$ . Calculate the height of P above the ground.

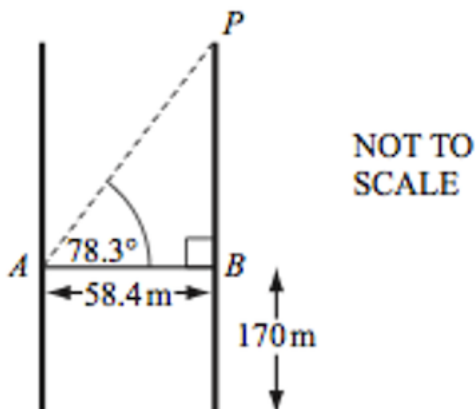

4. In the triangle ABC, right angled at B,  $\cos C = 4/5$ . Find the angle A.
5. In the diagram, BC represents a building 30m tall.  
A flagpole DC, stands on top of the building.  
From a point A, the angle of elevation of the top of the building is  $31^\circ$ .  
The angle of elevation of the top of the flagpole is  $37^\circ$ .

Calculate the height, DC of the flagpole.

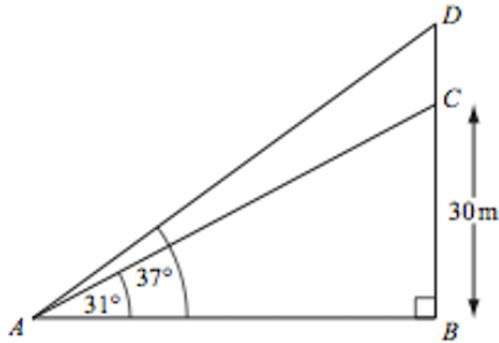

6. A ship sails from port P to port Q.  
Q is 74km from P on a bearing of  $142^\circ$ .  
A lighthouse L, is 58km from P on a bearing of  $110^\circ$ .
- (a) Show that the distance LQ is 39.5Km correct to 1 decimal place.  
(b) Use the sine rule to calculate angle PQL.  
(c) Find the bearing of P from Q & L from Q.  
(d) The ship takes 2 hours and 15 minutes to sail the 74km from P to Q.  
Calculate the average speed in knots. (1 knot = 1.85km/h)  
(e) Calculate the shortest distance from the lighthouse to the path of the ship.

7. Calculate the value of a.



8.  $\sin x = \cos 40^\circ$ ,  $0^\circ \leq x \leq 180^\circ$ .  
Find the value of x.

**KOTHARI INTERNATIONAL SCHOOL, NOIDA**  
**CAMBRIDGE ASSESSMENT INTERNATIONAL EDUCATION**  
**SESSION 2022-23, IGCSE 2 – MATHEMATICS (0580)**  
**PRACTICE ASSIGNMENT**

1. Solve the inequality  $3 < 2x - 5 < 7$ .

Answer \_\_\_\_\_

2. Work out as a single fraction:

$$\frac{2}{x-3} - \frac{1}{x+4}$$

Answer \_\_\_\_\_

3. A ferry has a deck area of 3600-meter square for parking cars and trucks. Each car takes up 20 sq. meter of deck area and each truck takes up 80 sq. meter. On one trip, the ferry carries  $x$  cars and  $y$  trucks.
- a) Show that this information leads to the inequality  $x + 4y \leq 180$ .
- b) The charge for the trip is \$25 for a car and \$50 for a truck.  
The total amount of money taken is \$3000.  
Write down an equation to represent this information and simplify it.
- c) The line  $x + 4y = 180$  is drawn on the grid below.
- (i) Draw, on the grid, the graph of your equation in part (b).



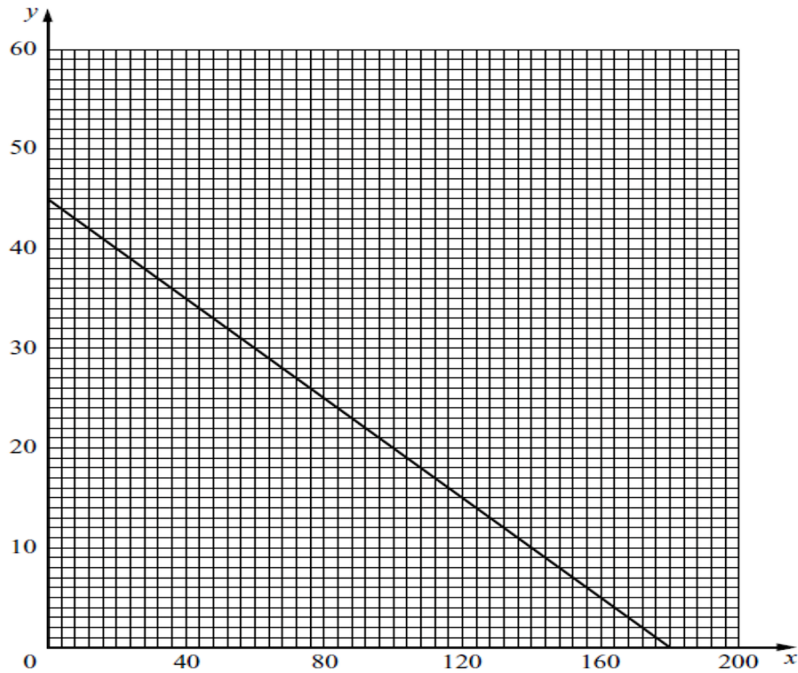

- (ii) Write down a possible number of cars and a possible number of trucks on the trip, which together satisfy both conditions.

4. Simplify :

$$\frac{2}{3}p^{12} x \frac{3}{4}p^8$$

5. Solve the equation:

$$\frac{x}{4} - 8 = -2$$

6. Solve the simultaneous equations:

$$\frac{1}{2}x + y = 5 \text{ and } x - 2y = 6$$

7. Make  $d$  the subject of the formula

$$c = k d^2 + e$$

8. (a) Factorise completely :  $12x^2 - 3y^2$ .

(b) Expand  $(x - 3)^2$

c)  $x^2 - 6x + 10$  is to be written in the form  $(x - p)^2 + q$ .

Find the values of  $p$  and  $q$ .

9. Solve the simultaneous equations:

$$\frac{1}{2}x + 2y = 16 \text{ and } 2x + \frac{1}{2}y = 19$$

10. Simplify :  $\frac{x+2}{x} - \frac{x}{x+2}$

Write your answer as a fraction in its simplest form.

11. Solve: (a)  $0.2x + 3.6 = 1.2$

(b)  $\frac{2-3x}{5} < x + 2$

12. Write as a single fraction in its simplest fraction:  $\frac{5}{x} - \frac{4}{x+1}$

13. Solve the simultaneous equations  $0.4x + 2y = 10$  and  $0.3x + 5y = 18$

14. Solve the equation  $\frac{x-2}{4} = \frac{(2x+5)}{3}$

15. Factorise :

- (a)  $4x^2 - 9$
- (b)  $4x^2 - 9x$
- (c)  $4x^2 - 9x + 2$

16.

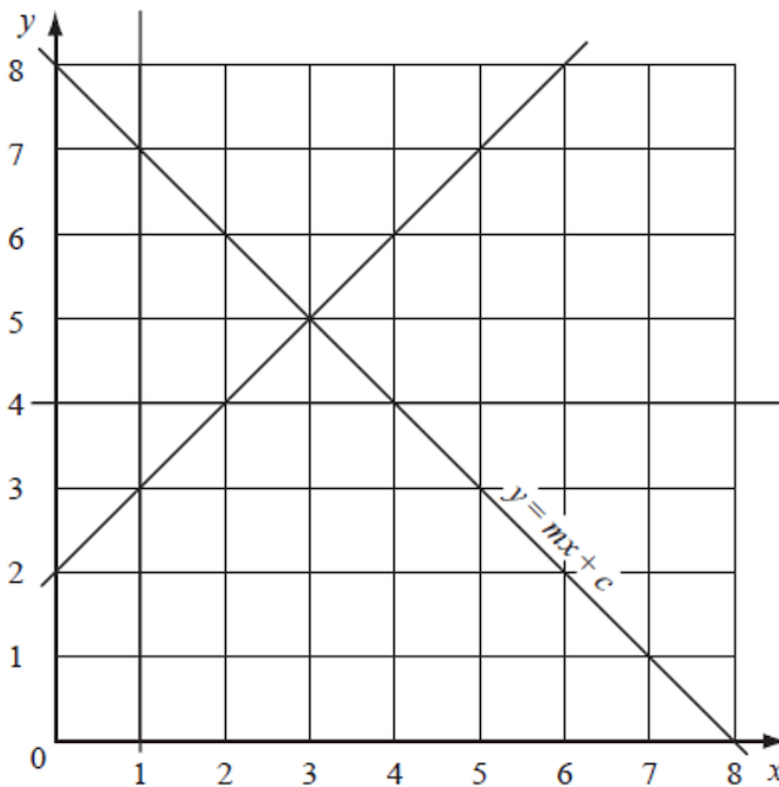

- a) One of the lines in the diagram is labelled  $y = mx + c$ . Find the values of  $m$  and  $c$ .
- b) Show, by shading all the unwanted regions on the diagram, the region defined by the inequalities.

$$x \geq 1, \quad y \leq mx + c, \quad y \geq x + 2 \quad \text{and} \quad y \geq 4$$

Write the letter R in the region required.

- 17. By shading the unwanted parts of the grid above, find and label the region R which satisfies the following three inequalities

$$y \geq 3, \quad y \geq 5x. \quad \text{and} \quad x + y \leq 6.$$

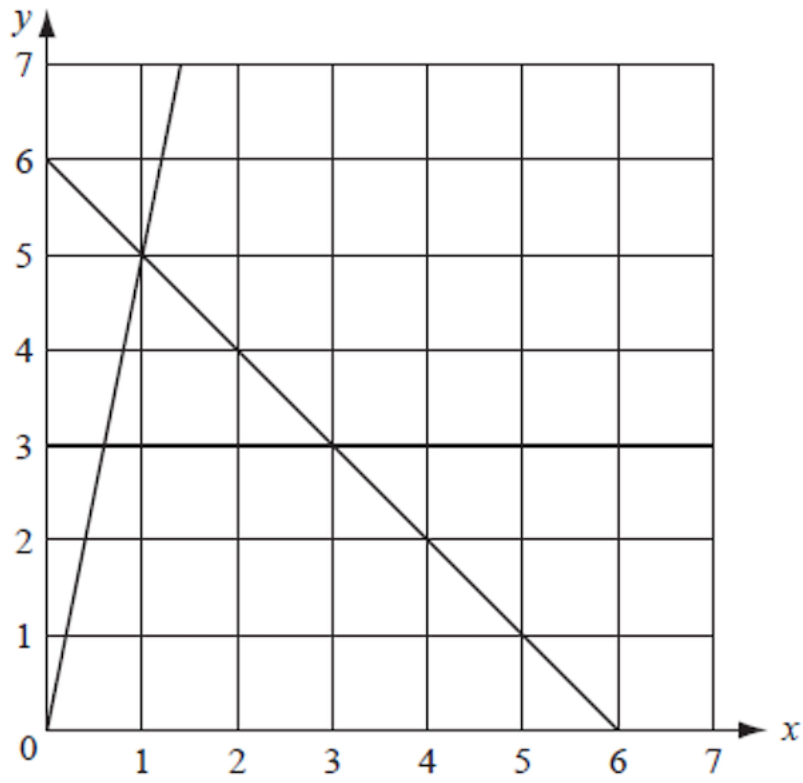

18. Solve the inequality :

$$\frac{2x-5}{8} > \frac{x+4}{3}$$

**KOTHARI INTERNATIONAL SCHOOL**  
**IGCSE-II**  
**WORKSHEET: DATABASE**

1 Give **three** benefits of using databases. [3 marks]

1 .....

.....

2 .....

.....

3 .....

.....

2 Explain the following terms used about databases. [4 marks]

Table: .....

.....

Record: .....

.....

Field: .....

.....

Primary key: .....

.....

3 A school keeps a database table (TEXTBOOK) of all the textbooks that are available for student use. The following information is stored for each set of books: the name of the textbook, the ISBN, the authors, the number of copies available for use, the subject it is used for.

a Select names and data types for each field in the table. [5 marks]

.....

.....

.....

.....

b i Name the fields that should be verified. [1 mark]

.....

ii Name the fields that should be validated. [1 mark]

.....

c Which field would you choose for the primary key and why would you choose it? [2 marks]

.....  
.....  
.....

d Give the validation rules you would use for each field that is to be validated. [4 marks]

.....  
.....  
.....  
.....  
.....

e A teacher wants to know the names of the textbooks available for a history class with 30 students in it.

Complete the query-by-example grid below to show the search condition required. [3 marks]

Field:			
Table:			
Sort:			
Show:	<input type="checkbox"/>	<input type="checkbox"/>	<input type="checkbox"/>
Criteria:			
or:			

# WORKSHEET: SOFTWARE

1 Give six functions of a typical operating system (OS). [6 marks]

- 1 .....
- 2 .....
- 3 .....
- 4 .....
- 5 .....
- 6 .....

2 a Describe three different types of interrupt. [3 marks]

- 1 .....
- .....
- 2 .....
- .....
- 3 .....
- .....

b What is meant by the term **buffer**? [1 mark]

- .....
- .....
- .....

c The flowchart on the opposite page shows how buffers and interrupts are used when the processor sends data to a printer. Some of the items are missing from the flowchart.

Using item numbers only, complete the flowchart using the following list of items: [6 marks]

Item number	Item
1	contents of printer buffer emptied to printer
2	current task is suspended while interrupt is serviced
3	data to be printed out is sent to the printer buffer
4	processor continues with its current tasks
5	processor continues with current tasks while printer buffer is emptied
6	when all the data is printed, printer buffer becomes empty

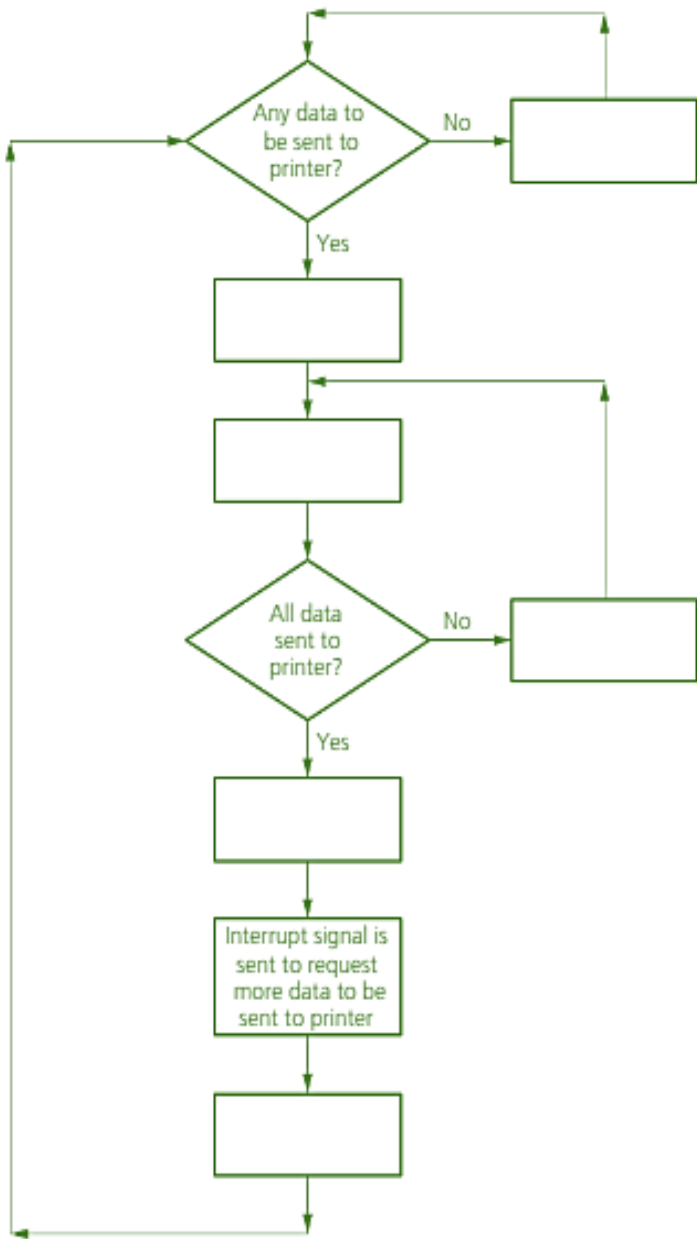

**KOTHARI INTERNATIONAL SCHOOL, NOIDA**  
**HOLIDAY ASSIGNMENT, SESSION: 2023-24**  
**GRADE: 10 IGCSE SUBJECT: GERMAN (0525)**  
**TOPIC: LISTENING**

**Erster Teil**

**Erste Aufgabe, Fragen 1–8**

In dieser Aufgabe hören Sie einige Bemerkungen oder Gespräche. Sie hören jede Bemerkung und jedes Gespräch zweimal. Suchen Sie die Antwort heraus, die am besten passt, und kreuzen Sie das richtige Kästchen an.

Inge fährt mit ihrem Freund Paul in den Urlaub.

1 Inge ruft Paul an. Sie sagt:

Womit fahren Inge und Paul in den Urlaub?

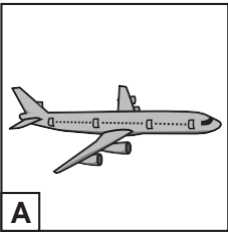
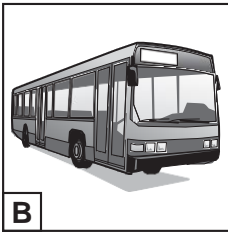
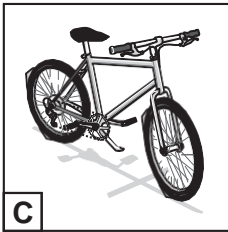
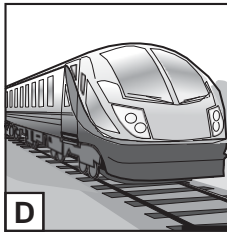
A	<input type="checkbox"/>				
B	<input type="checkbox"/>	A	B	C	D
C	<input type="checkbox"/>				
D	<input type="checkbox"/>				

2 Paul hat einen Vorschlag:

Was bringt Paul mit?

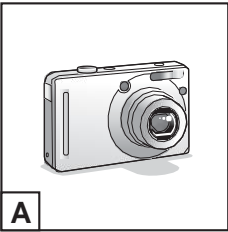
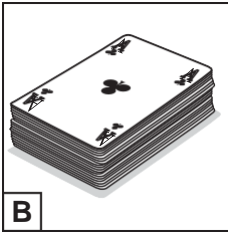
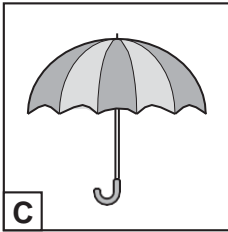
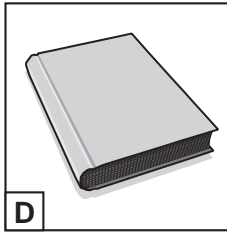
A	<input type="checkbox"/>				
B	<input type="checkbox"/>	A	B	C	D
C	<input type="checkbox"/>				
D	<input type="checkbox"/>				



3 Paul hat eine Frage:

Um wie viel Uhr wollen sie sich treffen?

A	
B	
C	
D	

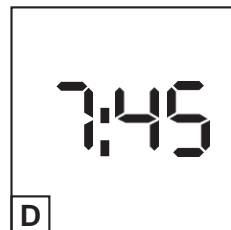
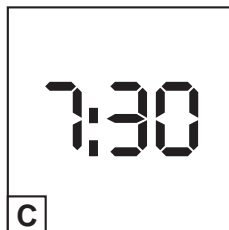
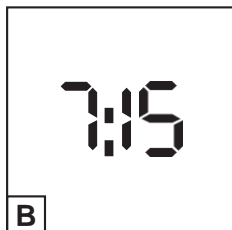
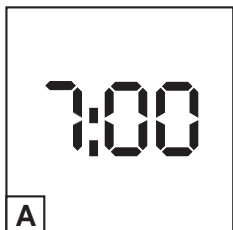

4 Paul hat noch eine Frage:

Was bringt Inge für die Reise mit?

A	
B	
C	
D	

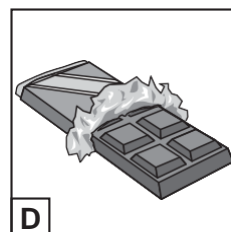
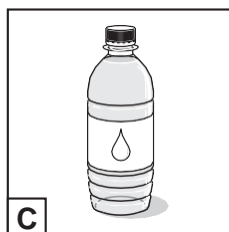
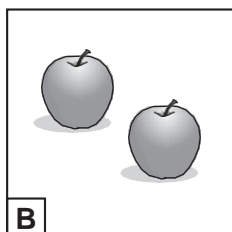
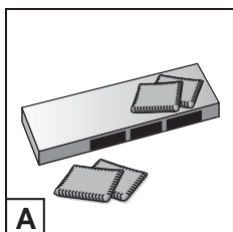

5 Inge und Paul diskutieren weiter:

Wo wohnen Inges Großeltern?

A	
B	
C	
D	

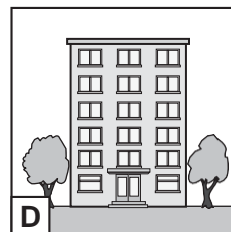
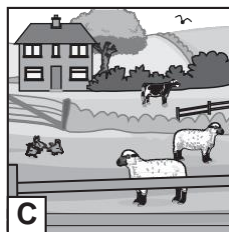
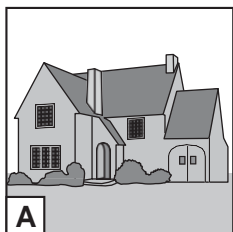

6 Inge ist froh. Sie sagt:

Wo verbringen Inge und Paul ein paar Tage?

A	
B	
C	
D	

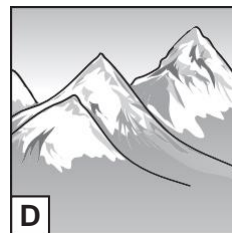
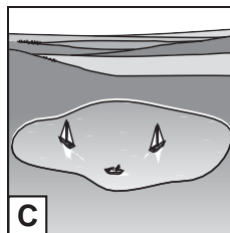
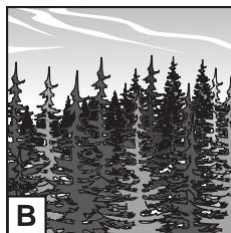
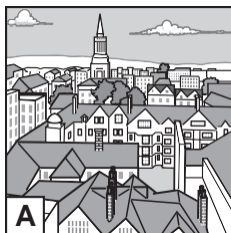

7 Paul hat eine Frage:

Wie ist das Wetter?

A	
B	
C	
D	

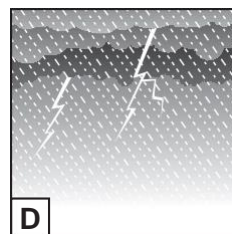
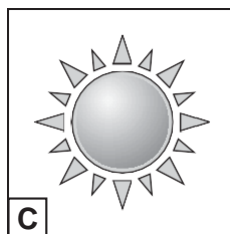
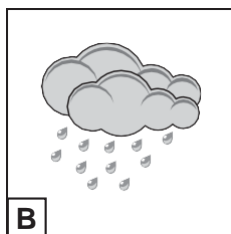
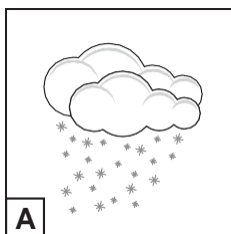

8 Inge hat eine Idee. Sie sagt:

Was macht Paul gern?

A	
B	
C	
D	

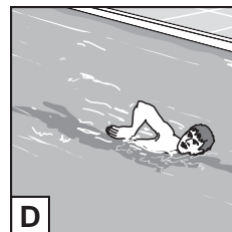
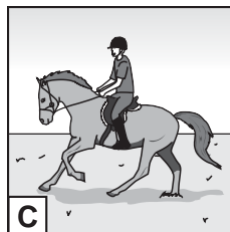
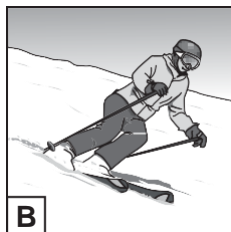
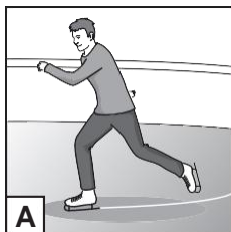

## Zweite Aufgabe, Fragen 9–15

Sie hören jetzt zweimal die Lokalnachrichten im Radio.

Während Sie zuhören, schreiben Sie die Antworten **auf Deutsch** oder **in Ziffern** und kreuzen Sie die richtigen Kästchen an.

Es gibt eine kurze Pause im Bericht.

Bevor Sie die Informationen hören, lesen Sie bitte die Fragen durch.

### Nachrichten aus Neudorf

9 Von welchem Tag sind die Nachrichten? (Kreuzen Sie 1 Kästchen an)

<input type="checkbox"/>	<b>19. April</b>	<input type="checkbox"/>	<b>19. Juni</b>	<input type="checkbox"/>	<b>19. August</b>
<input type="checkbox"/>	<b>A</b>	<input type="checkbox"/>	<b>B</b>	<input type="checkbox"/>	<b>C</b>

10 In welchem Land war der Kanu-Wettbewerb? .....

11 Warum kann man die B15 nicht benutzen? (Kreuzen Sie 1 Kästchen an)

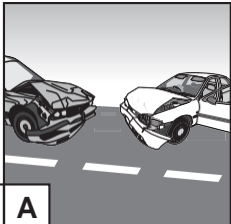
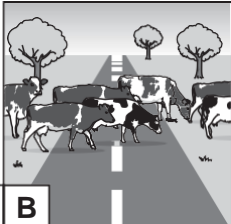
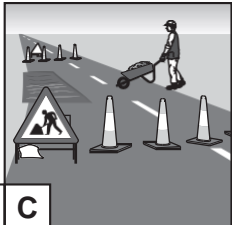
					
<input type="checkbox"/>	<b>A</b>	<input type="checkbox"/>	<b>B</b>	<input type="checkbox"/>	<b>C</b>

12 Aus welcher Zeit kommt die Popmusik? Aus den.....Jahren.

[PAUSE]

13 Die Kinder durften nicht mit dem Auto zur Schule kommen. Wer fand das schlecht?  
(Kreuzen Sie 1 Kästchen an)

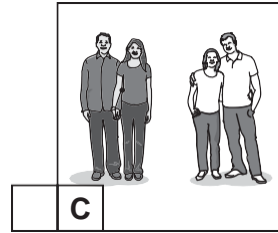
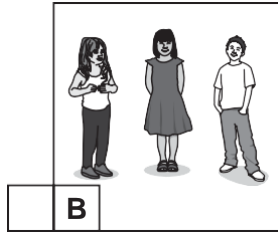
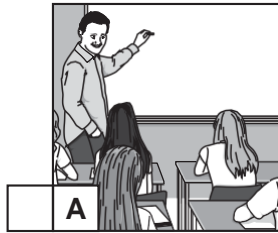

14 Was war die Spezialität im Restaurant *Mimo*? (Kreuzen Sie 1 Kästchen an)

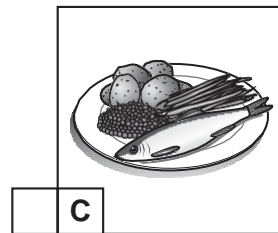
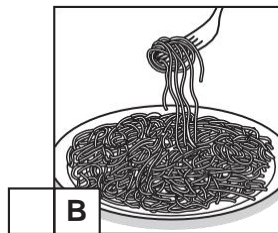
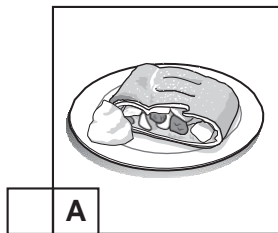

15 Was fotografiert Detlev Sperling? (Kreuzen Sie 1 Kästchen an)

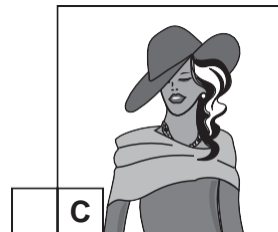
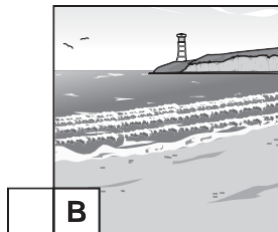
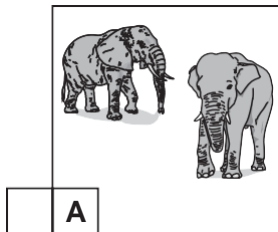

## Zweiter Teil

### Erste Aufgabe, Frage 16

Sie hören jetzt zweimal ein Interview mit vier Jugendlichen. Sie reden über das Thema Geschenke.

Während Sie zuhören, kreuzen Sie an, wenn die Aussage **richtig** ist.

Kreuzen Sie **nur 6 Kästchen** an (✓✓✓✓✓✓).

Bevor Sie das Interview hören, lesen Sie bitte die Aussagen durch.

#### Henrik

- (a) Henrik findet es langweilig, Geld zum Geburtstag zu bekommen.
- (b) Seine Verwandten kaufen für ihn meistens Bücher.
- (c) Er bekommt nicht gern Kleidung als Geschenk.

Richtig

#### Anja

- (d) Anja hat Anfang Dezember Geburtstag.
- (e) Als Kind hat es ihr nicht gefallen, im Dezember Geburtstag zu haben.
- (f) Jetzt ist sie mit ihren Geschenken zufrieden.

#### Jan

- (g) Jans Tante hat wunderschönes Spielzeug für ihn gekauft.
- (h) Jan will sich jetzt nicht mehr überraschen lassen.
- (i) Er kauft gern Geschenke für seinen Opa.

#### Marta

- (j) Marta sucht gern Geschenke für Kinder aus.
- (k) Für ihre Schwester hat sie ein Bild gemalt.
- (l) Geschenke für ihre Familie sind meistens selbstgemacht.

## Zweite Aufgabe, Fragen 17–25

Sie hören jetzt zwei Interviews über das Mittagessen in der Schule. Nach jedem Interview gibt es eine Pause.

### Interview Nummer 1: Fragen 17–21

Jetzt hören Sie zweimal ein Interview mit Frau Meyer.

In jedem Satz gibt es ein Wort, Wörter oder eine Ziffer, die nicht zu dem Sinn des Interviews passen. Hören Sie gut zu und schreiben Sie jedes Mal das richtige Wort / die richtigen Wörter **auf Deutsch** oder die richtige Ziffer.

Bevor Sie zuhören, lesen Sie bitte die Fragen 17-21 durch.

17 Frau Meyer hat elf ~~Grundschulen~~ besucht.

.....

18 Pro Jahr und pro Schüler landen ~~15~~ Kilogramm Essen im Müll.

.....

19 Wenn man so viel Essen wegwirft, ist das nicht nur teuer, sondern auch schlecht für die ~~Gesundheit~~.

.....

20 Die Schüler waren ~~gelangweilt~~, als sie hörten, wie viel Essen im Müll landete.

.....

21 Die Schüler haben mit den ~~Eltern~~ diskutiert, was sie machen können.

.....

[PAUSE]

## Interview Nummer 2: Fragen 22–25

Jetzt hören Sie zweimal ein Interview mit Anne, einer Schülerin.

Hören Sie gut zu und beantworten Sie die Fragen **auf Deutsch**.

Bevor Sie zuhören, lesen Sie bitte die Fragen 22-25 durch.

**22** Wie findet Anne die Gerichte in der Kantine?

.....

**23** Was findet Anne stressig in der Kantine? Nennen Sie **einen** Punkt.

.....

**24** Warum kann Anne nicht immer richtig essen?

.....

**25** Welches Problem hat Anne, wenn sie hungrig ist?

.....

## Dritter Teil

### Erste Aufgabe, Fragen 26–31

Jetzt hören Sie zweimal ein Interview mit Rita Neumann, einer Pilotin.

Hören Sie gut zu und beantworten Sie die Fragen.

Sie haben für jede Frage vier Antworten zur Auswahl. Suchen Sie die Antwort heraus, die am besten passt, und kreuzen Sie das richtige Kästchen an.

Es gibt eine Pause im Interview.

Bevor Sie das Interview hören, lesen Sie bitte die Fragen und Antworten durch.

**26** Frau Neumann arbeitet als Pilotin, ...

- A**  weil es immer ihr Traumjob war.
- B**  aber als Kind wollte sie in Filmen mitspielen.
- C**  um Geld für das Studium zu verdienen.
- D**  obwohl sie Flughäfen nicht mag.

**27** Frau Neumann ...

- A**  hat die Hälfte des Monats frei.
- B**  ist die ganze Zeit unterwegs.
- C**  hat zwischen den Flügen immer fünf Tage frei.
- D**  wird nie müde.

**28** Frau Neumann ...

- A**  ist nie nach Neuseeland gereist.
- B**  wird bald Südamerika besuchen.
- C**  sieht am liebsten die Städte.
- D**  besichtigt die meisten Touristenziele.

[PAUSE]



**29** Die meisten Fluggäste ...

- A**  sind unfreundlich.
- B**  haben keine Angst vor dem Fliegen.
- C**  mögen keinen Lärm im Flugzeug.
- D**  haben kein Problem mit schreienden Babys.

**30** Frau Neumann findet Fliegen ...

- A**  ab und zu stressig.
- B**  beruhigend.
- C**  gefährlicher als das Autofahren.
- D**  im Großen und Ganzen gesund.

**31** Frau Neumann möchte ...

- A**  in zehn Jahren ihren Beruf als Pilotin aufgeben.
- B**  zukünftig mehr Zeit für ihr Hobby haben.
- C**  in der Zukunft Deutschland nicht mehr verlassen.
- D**  später nie wieder mit dem Flugzeug reisen.

**Zweite Aufgabe, Fragen 32–39**

Jetzt hören Sie zweimal ein Interview mit Thorsten über sein Leben zu Hause.

Hören Sie gut zu und beantworten Sie die Fragen **auf Deutsch**.

Es gibt zwei Pausen im Interview.

Bevor Sie das Interview hören, lesen Sie bitte die Fragen durch.

**32** Warum wohnt Thorstens Vater nicht mehr in der Familienwohnung?

.....

**33** Was für einen Beruf hat Thorstens Mutter?

.....

**34** Warum wollte Thorsten in der Familienwohnung bleiben?

.....

[PAUSE]

**35** Wie hat Thorstens Mutter die ersten Wochenenden verbracht? Nennen Sie **einen** Punkt.

.....

**36** Warum sind die Wochenenden jetzt besser?

.....

**37** Was kann Thorsten kochen? Nennen Sie **ein** Beispiel.

.....

[PAUSE]

38 Warum geht Thorsten gern in die Schule? Nennen Sie **einen** Grund.

.....

39 Wann findet Thorsten seine Situation nicht so schön? Nennen Sie **zwei** Beispiele.

(i).....

(ii).....

**Link of the Audio:**

[https://dynamicpapers.com/wp-content/uploads/2015/09/0525\\_s19\\_su\\_12.mp3](https://dynamicpapers.com/wp-content/uploads/2015/09/0525_s19_su_12.mp3)

**KOTHARI INTERNATIONAL SCHOOL, NOIDA**  
**HOLIDAY ASSIGNMENT, SESSION: 2023-24**  
**GRADE: 10 IGCSE SUBJECT: GERMAN (0525)**  
**TOPIC: WRITING**

- 1 Sie wollen ins Museum gehen, und Sie bestellen Karten.

Füllen Sie das Formular **auf Deutsch** aus.

KARTENBESTELLUNG

Welche Ausstellung:	<i>Dinosaurier</i>
Datum:	<b>(1)</b> <i>Montag, der 12..... 2022</i>
Für wie viele Personen?	<b>(2)</b> <i>Für drei Erwachsene und vier .....</i>
Wie lange möchten Sie bleiben?	<b>(3)</b> .....
Was planen Sie im Museumsshop zu kaufen?	<b>(4)</b> ..... <i>und</i> <b>(5)</b> .....
Umweltinfo: Wie reisen Sie an?	<i>mit der U-Bahn</i>





A series of 25 horizontal dotted lines for writing.

**KOTHARI INTERNATIONAL SCHOOL, NOIDA**  
**HOLIDAY ASSIGNMENT, SESSION: 2023-24**  
**GRADE: 10 IGCSE SUBJECT: GERMAN (0525)**  
**TOPIC: NEBENSÄTZE**

**Ü1. Vervollständige die Sätze mit ‚zu‘ oder ‚um zu‘**

1. Ich habe Lust, \_\_\_\_\_
2. Ich lerne jeden Tag für die Prüfung, \_\_\_\_\_
3. Am Wochenende habe ich frei, \_\_\_\_\_
4. Im Unterricht ist es verboten, \_\_\_\_\_
5. Ich treibe viel Sport, \_\_\_\_\_

**Ü2. Verbinde die Sätze mit ‚wenn‘ oder ‚damit‘**

1. Ich lerne bis spät in der Nacht. Ich habe Prüfungen.  
\_\_\_\_\_
2. Es regnet. Ich gehe gern spazieren.  
\_\_\_\_\_
3. Ich gehe regelmäßig in die Schule. Ich kann lernen.  
\_\_\_\_\_
4. Ich habe Geburtstag. Ich gehe mit Freunden ins Cafe.  
\_\_\_\_\_
5. Ich suche E-Mailfreunde. Ich kann meine Sprachkenntnisse verbessern.  
\_\_\_\_\_

**Ü3. Ergänze die Nomen und Artikel in der richtigen Form (Genetiv)**

1. Während \_\_\_\_\_ (Pause) dürfen die Schüler nicht in der Klasse bleiben.
2. Während \_\_\_\_\_ (Unterricht) müssen die Schüler zuhören.
3. Hast du die Hefte \_\_\_\_\_ (Studenten)?
4. Das ist das Auto \_\_\_\_\_ (Vater).

**Ü4. Ergänze die Artikel im Genetiv und Endungen, wo nötig**

1. Das Baby d \_\_\_\_\_ Vater \_\_\_\_\_
2. Der Freund d \_\_\_\_\_ Frau \_\_\_\_\_
3. Die Bücher d \_\_\_\_\_ Kinder \_\_\_\_\_
4. Die Puppe d \_\_\_\_\_ Mädchen \_\_\_\_\_





Summer Break Holiday Home Work

IGCSE X

CHEMISTRY

STRUCTURED QUESTIONS

Q 1.

Dilute nitric acid behaves as a typical acid in some reactions but **not** in other reactions.

- (a) Dilute nitric acid behaves as a typical acid when reacted with copper(II) oxide and with copper(II) carbonate.

Describe what you would **see** if excess dilute nitric acid is added separately to solid samples of copper(II) carbonate and copper(II) oxide followed by warming the mixtures.

copper(II) carbonate

.....  
.....

copper(II) oxide

.....  
.....

[4]

- (b) When dilute nitric acid is added to pieces of copper and heated, a reaction takes place and copper(II) nitrate is formed.

- (i) Part of the chemical equation for the reaction between copper and dilute nitric acid is shown.

Complete the chemical equation by inserting the formula of copper(II) nitrate and balancing the equation.

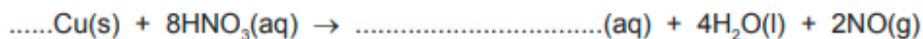

[2]

- (ii) How is the reaction of dilute nitric acid with copper different from that of a typical metal with a typical acid?

.....  
..... [1]

[Total: 7]

**Q. 2.**

When lead(II) nitrate is heated, two gases are given off and solid lead(II) oxide remains.  
The equation for the reaction is shown.

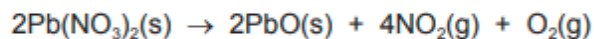

**(a)** Calculate the  $M_r$  of lead(II) nitrate.

..... [1]

**(b)** 6.62g of lead(II) nitrate are heated until there is no further change in mass.

**(i)** Calculate the mass of lead(II) oxide produced.

..... g [2]

**(ii)** Calculate the volume of oxygen,  $\text{O}_2$ , produced at room temperature and pressure (r.t.p.).

.....  $\text{dm}^3$  [2]

**(c)** Describe a test for oxygen.

test .....

result .....

[2]

[Note: Atomic Masses: Lead(Pb) =207; N=14; O=16]

(d) Lead(II) oxide is insoluble. A student adds solid lead(II) oxide to dilute nitric acid until the lead(II) oxide is in excess. Aqueous lead(II) nitrate and water are produced.

(i) What is meant by the term *excess*?

..... [1]

(ii) How would the student know when the lead(II) oxide is in excess?

..... [1]

(iii) Write a chemical equation for the reaction.

..... [1]

[Total: 10]

**Q. 3. Read the class notes on chemical reactions involving reversible reactions and equilibrium.**

Sulfuric acid can be manufactured from the raw materials sulfur, air and water. The process can be divided into four stages.

**stage 1** converting sulfur into sulfur dioxide

**stage 2** converting sulfur dioxide into sulfur trioxide

**stage 3** converting sulfur trioxide into oleum,  $\text{H}_2\text{S}_2\text{O}_7$

**stage 4** converting oleum into sulfuric acid

**stage 1**

(a) (i) Describe how sulfur is converted into sulfur dioxide.

..... [1]

(ii) Write a chemical equation for the conversion of sulfur into sulfur dioxide.

..... [1]

**stage 2**

(b) Sulfur dioxide is converted into sulfur trioxide according to the following equation.



The reaction is carried out at a temperature of 450°C and a pressure of 1–2 atmospheres using a catalyst. The energy change,  $\Delta H$ , for the reaction is  $-196 \text{ kJ/mol}$ .

(i) What is the meaning of the symbol  $\rightleftharpoons$ ?

..... [1]

(ii) Name the catalyst used in this reaction.

..... [1]

(iii) Why is a catalyst used?

..... [1]

(iv) If a temperature higher than 450°C were used, what would happen to the amount of sulfur trioxide produced? Give a reason for your answer.

.....  
..... [2]

(v) Suggest a reason why a temperature lower than 450°C is **not** used.

.....  
..... [1]

(vi) If a pressure higher than 1–2 atmospheres were used, what would happen to the amount of sulfur trioxide produced? Give a reason for your answer.

.....  
..... [2]

**stage 4**

(d) (i) What is added to oleum to convert it into sulfuric acid?

..... [1]

(ii) Write a chemical equation for the conversion of oleum into sulfuric acid.

..... [1]

(e) Give **one** use of sulfuric acid.

..... [1]

(f) Sulfuric acid reacts with a hydrocarbon called benzene to produce benzenesulfonic acid,  $C_6H_5SO_3H$ . Benzenesulfonic acid is a strong acid which ionises to produce hydrogen ions,  $H^+$ , and benzenesulfonate ions,  $C_6H_5SO_3^-$ .

(i) What is meant by the term *strong acid*?

..... [1]

(ii) Describe how to show that a  $1\text{ mol/dm}^3$  solution of benzenesulfonic acid is a strong acid.

.....  
..... [2]

(iii) Write a chemical equation for the reaction between benzenesulfonic acid and sodium carbonate,  $Na_2CO_3$ .

..... [2]

[Total: 20]

Q. 4.

Write down the general formula of each of the following classes of organic compounds, Write also the structural and displayed formula of any one compound in each class. The general formulae of classes from 4 – 9 below should be written in terms of "R", the Alkyl Radical.

1. Alkanes

2. Alkenes

3. Alkynes

4. Alcohols

5. Aldehydes

6. Ketones

7. Carboxylic acids

8. Esters

9. Primary Amines

# SPANISH

## Reading

1 Mira los dibujos.

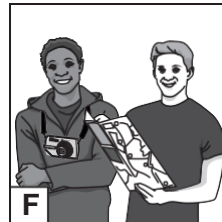
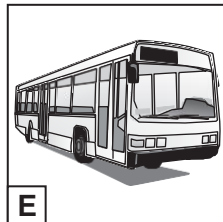
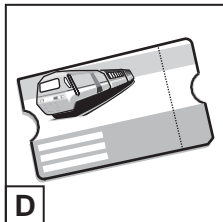
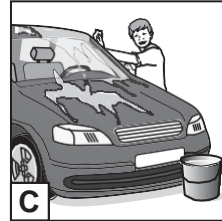
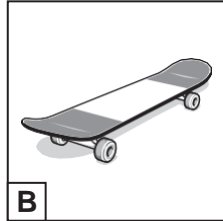
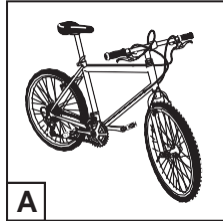

Para cada pregunta escribe la letra correcta (A–F) en la casilla.

(a) Enrique siempre va al colegio en autobús.

[1]

(b) Este domingo Iván va a lavar el coche.

[1]

(c) En la ciudad de Hugo hay muchos turistas.

[1]

(d) Mario necesita un billete de tren para Madrid.

[1]

(e) Eduardo tiene una bicicleta nueva.

[1]

[Total: 5]



2 Lee los letreros.

**En la biblioteca**

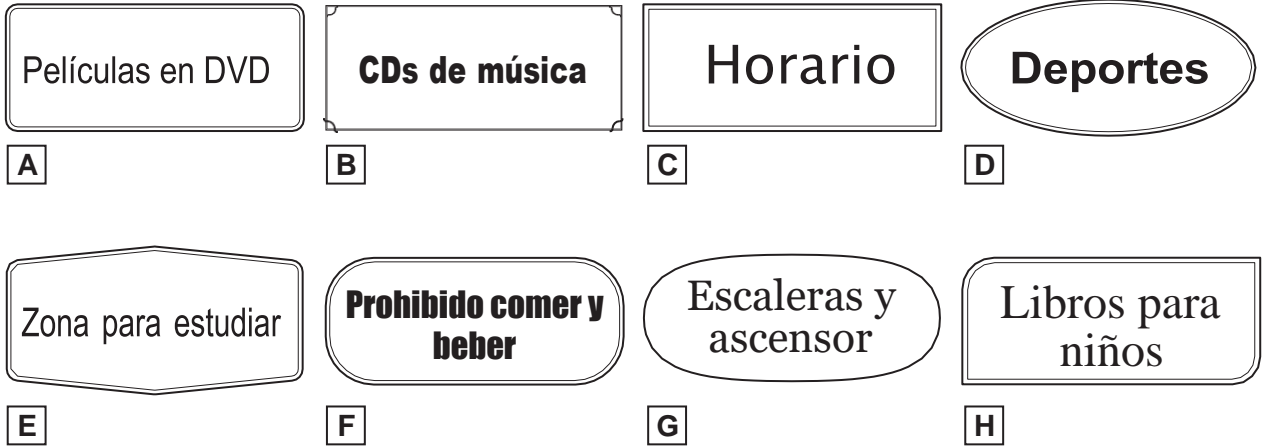

Para cada pregunta escribe la letra correcta (A–H) en la casilla.

- |   |                          |     |
|---|--------------------------|-----|
| (a) Necesito ir al segundo piso.                        | <input type="checkbox"/> | [1] |
| (b) Quiero ver una comedia en casa.                     | <input type="checkbox"/> | [1] |
| (c) Me encanta escuchar canciones modernas.             | <input type="checkbox"/> | [1] |
| (d) Voy a leer algo sobre mi equipo favorito.           | <input type="checkbox"/> | [1] |
| (e) Normalmente hago mis deberes aquí después de clase. | <input type="checkbox"/> | [1] |

[Total: 5]

- 3 Lee el texto. Para cada pregunta indica tu respuesta escribiendo una **X** en la casilla correcta (**A–C**).

Siempre me gusta cocinar y a veces preparo postres. Suelo hacer tartas para el cumpleaños de mi madre o el de mi padre. Mi hermano me ayuda.

Ayer preparamos una pequeña tarta de chocolate deliciosa porque era el cumpleaños de mi madre. Ella se puso muy alegre al verla. Desafortunadamente, yo no pude probarla porque me pongo malo si como chocolate.

De niño podía comer chocolate pero hace tres años estuve en el hospital durante una semana después de comerlo. El médico me dijo que tenía alergia al chocolate. Por eso, cuando salimos a cenar los fines de semana, de postre pido helado. Prefiero el de fresa. En casa me encanta comer la tarta de manzana que hace mi madre.

Moisés

- (a) Moisés cocina postres ...

A de vez en cuando.

B siempre.

C una vez al año.

[1]

- (b) Moisés prepara tartas con ...

A su padre.

B su primo.

C su hermano.

[1]

- (c) La tarta que Moisés hizo ayer ...

A estaba muy buena.

B era bastante grande.

C estaba demasiado dulce.

[1]

(d) Cuando vio su tarta de cumpleaños, la madre de Moisés se sintió ...

A decepcionada.

B contenta.

C nerviosa.

[1]

(e) Moisés no come chocolate porque ...

A no le gusta mucho.

B se pone enfermo.

C no es una comida sana.

[1]

(f) Moisés suele comer helado ...

A en el cine.

B en restaurantes.

C en la playa.

[1]

(g) Cuando **no** sale, el postre preferido de Moisés es ...

A la tarta de manzana.

B el yogur de fresa.

C la tarta de queso.

[1]

[Total: 7]

4 Lee el texto. Contesta a las preguntas **en español**.

### Excursión al Parque Nacional

En agosto, para recordar viejos tiempos, Begoña y Andrea Pérez, dos hermanas chilenas de 60 y 61 años, tuvieron la idea de hacer una excursión al Parque Nacional de la Castellana, famoso por su río. "Han pasado 50 años desde que visitamos el parque con nuestra familia," dijo Andrea.

Primero, alquilan un coche y, como los campings les parecían incómodos, reservaron una habitación en un hotel. El viaje hasta el parque duró tres horas y, en cuanto llegaron, miraron el paisaje.

Luego, Begoña abrió su mochila para sacar el mapa. "¡Qué mal!" dijo al darse cuenta de que lo había olvidado. Como tenían frío, en vez de ponerse los abrigos, decidieron esperar en el coche un rato. Aún peor, estaba a punto de llover.

Poco después, una chica paró a hablar con ellas. Cuando le dijeron que no sabían cómo ir al río, insistió en acompañarlas. Después de media hora, llegaron allí con la ayuda de la chica, que conocía la zona. "¿Por qué no hacemos una foto aquí como la que nos hizo nuestro tío?" dijo Begoña. Dieron las gracias a la chica que, antes de irse, les recomendó subir a la colina cercana para ver las hermosas vistas del mar.

En el camino de vuelta, las hermanas se perdieron. Por suerte, antes de anoecer, encontraron el coche. "¡Qué cansadas estamos! ¿Verdad?" dijo Andrea. Al día siguiente hablaron con el ayuntamiento y, gracias a ellas, se van a poner más señales en el parque. "¡Así la próxima vez no nos perderemos!" dijo Begoña.

(a) ¿Para qué fueron de excursión Begoña y Andrea al Parque Nacional?

..... [1]

(b) ¿Cuánto tiempo hacía que Begoña y Andrea fueron al Parque Nacional con su familia?

..... [1]

(c) ¿Por qué quisieron alojarse en un hotel Begoña y Andrea?

..... [1]

(d) ¿Qué fue lo primero que hicieron Begoña y Andrea en el Parque Nacional?

..... [1]

(e) ¿Qué descubrió Begoña cuando abrió su mochila?

..... [1]

(f) ¿Por qué decidieron quedarse en el coche Begoña y Andrea un poco más? (Menciona **dos** razones.)

1. .... [1]

2. .... [1]

(g) ¿Cómo encontraron el río Begoña y Andrea?

..... [1]

(h) ¿Quién tomó la foto a Begoña y Andrea junto al río cuando eran pequeñas?

..... [1]

(i) ¿Qué se veía desde la colina?

..... [1]

(j) ¿Cómo se sintieron por la noche Begoña y Andrea?

..... [1]

(k) ¿Qué se va a hacer para mejorar el Parque Nacional?

..... [1]



[Total: 12]

5 Lee los textos (a–e) y los anuncios (1–8).

¿En qué tienda deberían comprar la ropa que necesitan estas personas?

Para cada texto (a–e) escribe el número correcto (1–8) en la línea.

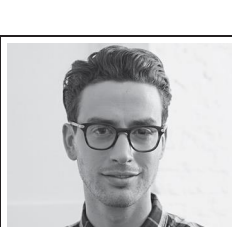
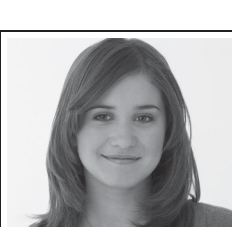
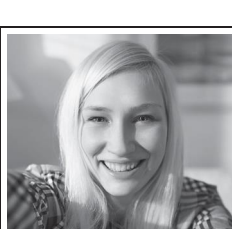
**Dónde comprar ropa**

<p>a</p> 	<p>IRENE: En septiembre iré a un instituto donde no hay uniforme, pero antes iré de vacaciones este verano y necesito un bañador. No me gusta comprar ropa en la red.</p>	<p>.....</p>
<p>b</p> 	<p>TOMÁS: Normalmente mi hijo pequeño lleva ropa deportiva, pero el próximo fin de semana iremos a la boda de mi mejor amiga. Él tendrá que llevar algo elegante.</p>	<p>.....</p>
<p>c</p> 	<p>YOLANDA: He conseguido un trabajo y necesito ropa para la oficina. Prefiero comprar en Internet porque hay ofertas. No me gusta la idea de comprar ropa que otra gente ya ha llevado.</p>	<p>.....</p>
<p>d</p> 	<p>SILVIA: Soy muy deportista y me encanta surfear, pero pronto voy a ser madre. Ahora necesito ropa para futuras madres y para mi bebé. Quiero comprar todo en una sola página web.</p>	<p>.....</p>
<p>e</p> 	<p>RAÚL: En la universidad siempre llevo sudaderas y pantalones de deporte. No tengo mucho dinero así que quiero comprar unas zapatillas rebajadas para hacer footing. No se me da bien comprar en Internet.</p>	<p>.....</p>

- 1 En nuestra tienda encontrarás todo lo necesario para salir a correr al mejor precio. A la hora de hacer deporte, ¡también es importante vestir bien! Además, esta semana, si eres estudiante, tenemos descuentos para ti.
- 2 La mejor manera de reciclar ropa y ayudar a proteger la naturaleza es comprar ropa usada. Tenemos una gran selección de ropa para ir a la oficina que limpiamos y reparamos antes de vender.
- 3 Si te gusta la playa o la piscina y necesitas un traje de baño, en nuestra tienda tenemos unos bonitos modelos hechos de materiales reciclados. Para hombres y mujeres, tallas grandes y pequeñas... ¡los tenemos para todos!
- 4 ¡Ya han llegado las rebajas a nuestra tienda en la red! Vendemos ropa para recién nacidos y ropa informal para tus hijos. Recuerda que en nuestra tienda también encontrarás ropa para embarazadas.
- 5 En nuestra tienda encontrarás trajes y vestidos para ocasiones especiales incluso para los niños. No traemos ropa de países extranjeros porque nos gusta cuidar el planeta. ¡Así se evitan los gases que dañan el planeta!
- 6 ¿Vas a casarte y aún no tienes traje? ¿Necesitas ahorrar para tu viaje de novios? En nuestra tienda alquilamos trajes de novio o novia a un precio muy económico. ¡Tenemos una gran variedad!
- 7 Si necesitas vestir bien, en nuestra tienda tenemos la mejor moda de hombre y de mujer para ir elegante al trabajo. Además, si compras en nuestra página de Internet, te haremos un regalo.
- 8 En nuestra tienda de Internet encontrarás las mejores marcas de bañadores para hombres y mujeres por poco dinero. Y si no te importa pagar un poco más, también tenemos las mejores marcas de ropa para hacer deporte.

6 Lee el texto. Contesta a las preguntas **en español**.

Hoy por primera vez el público de España puede ver la película *Besos de cuento*, la última película del actor más famoso de Argentina, Lisandro Baroja. La película ya ha tenido muchísimo éxito en el país donde nació y, según dicen, es la mejor comedia del año. “Aunque no quiero ser conocido como actor de comedias en el futuro, trabajé con actores muy graciosos. Me divertí mucho,” dice Lisandro.

Antes de ser actor, Lisandro era camarero. “Empecé con 16 años en el restaurante de mis abuelos. Aunque lavar platos me aburría, me gustaba charlar con los clientes. Al principio ganaba poco dinero, pero luego gané suficiente para pagar mis estudios de arte dramático,” comenta Lisandro orgulloso.

Después de terminar la universidad, Lisandro tuvo la suerte de conseguir su primer trabajo de actor en seguida. Un día, mientras trabajaba en el restaurante, conoció al director Rubén Hergueta, que entró para tomar unas tapas y lo invitó a hacer unas pruebas para una película al día siguiente. Cuando hizo la prueba, no solo tenía un resfriado horrible sino que, además, llegó al estudio muy nervioso. Nunca pensó que podría participar en películas tan pronto. No obstante, una semana después, recibió una llamada. Era Rubén, que quería darle su primer papel. Desde esa película de acción, *La isla de los tigres grises*, ha aparecido en otras 10 películas.

Ahora Lisandro vive en Madrid y está actuando en una serie de televisión que estará lista para el año próximo. “Todavía ayudo en el restaurante cuando visito a mi familia y, claro, hago la compra como todo el mundo. Sin embargo, lo que me fastidia de esta profesión es la gente que me conoce por la calle. Otro problema son las revistas de famosos. A veces son muy desagradables,” dice Lisandro.

En una reciente entrevista Lisandro comentó: “Si algún día me va mal en el mundo del cine, ¡abriré un restaurante en Madrid!”





- (a) ¿Dónde salió primero la película *Besos de cuento*?  
..... [1]
- (b) ¿Por qué se divirtió Lisandro trabajando en la película *Besos de cuento*?  
..... [1]
- (c) ¿A quién pertenecía el restaurante en el que Lisandro trabajaba?  
..... [1]
- (d) ¿Por qué no le gustaba fregar platos a Lisandro?  
..... [1]
- (e) ¿Para qué fue Rubén Hergueta al restaurante donde trabajaba Lisandro?  
..... [1]
- (f) ¿Cómo se sentía Lisandro el día de la prueba para su primera película? (Menciona **dos** detalles.)
1. .... [1]
2. .... [1]
- (g) ¿Para qué contactó Rubén a Lisandro después de la prueba?  
..... [1]
- (h) ¿Qué le molesta a Lisandro de ser actor? (Menciona **dos** detalles.)
1. .... [1]
2. .... [1]
- (i) Si deja de ser actor en el futuro, ¿qué hará Lisandro?  
..... [1]

[Total: 11]

## Writing

- 1 Tu amiga, Sara, quiere buscar una amiga por carta en un país hispanohablante. Ayuda a Sara a completar la ficha con su información personal **en español**.

Nombre y apellido:	Sara Pérez
Tu país:	.....
Tu profesión:	estudiante
Pasatiempos favoritos:	baloncesto y .....
Tu personalidad:	divertida y .....
Familia:	dos hermanos
Animales en casa: (Menciona <b>dos</b> animales.)	..... y .....
Número de teléfono:	0834772197





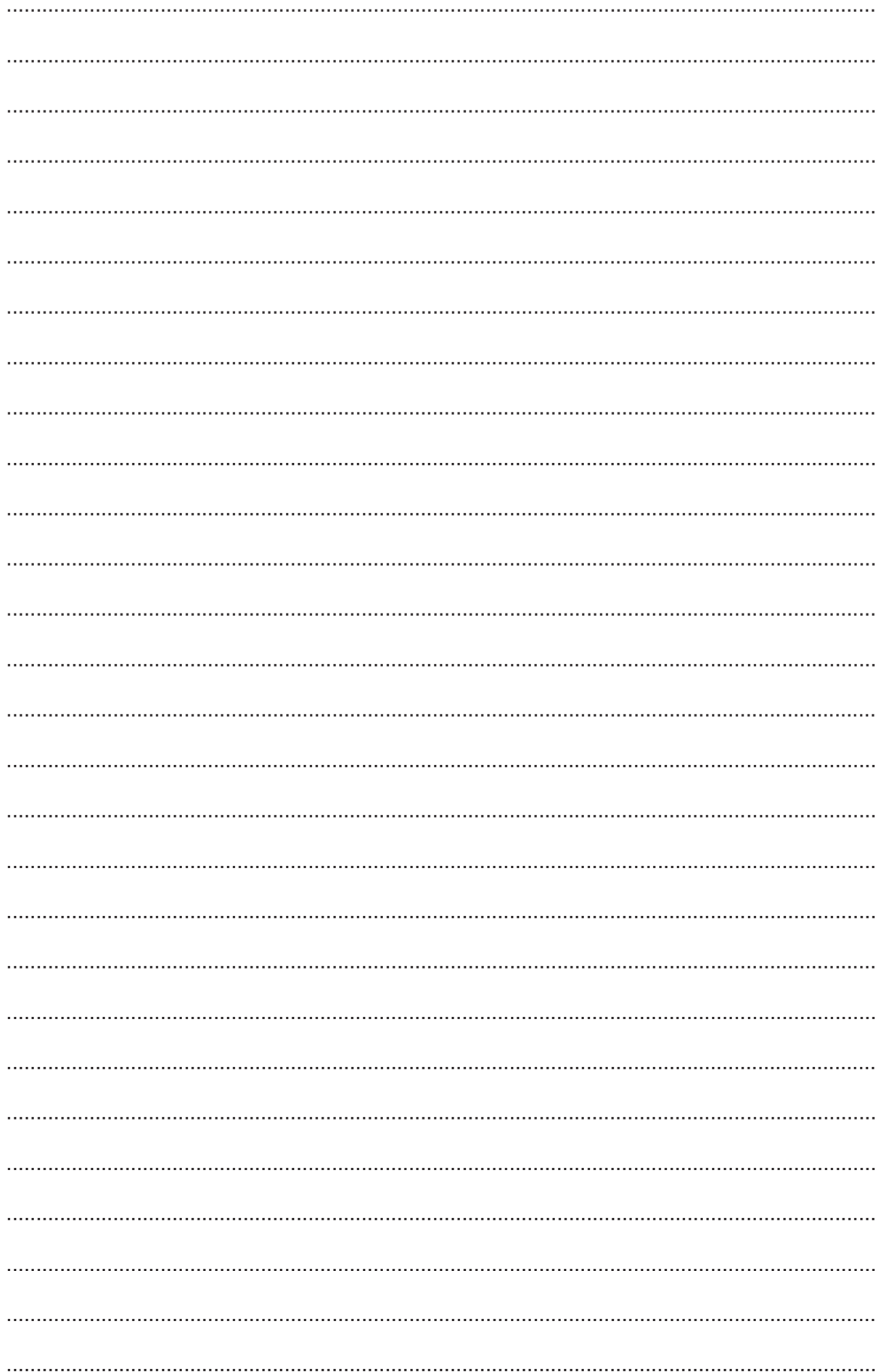

**INFORMATION**

- This insert contains the reading texts.
- You may annotate this insert and use the blank spaces for planning. **Do not write your answers** on the insert.

Read **Text A**, and then answer **Questions 1(a)–1(e)** on the question paper.

**Text A: Space travel**

*Humankind is becoming increasingly interested in space travel. This offers both challenges and rewards.*

‘One small step for a man; one giant leap for mankind.’ Neil Armstrong’s words, broadcast to the world as he stepped onto the Moon in 1969, became a defining phrase of the twentieth century. They marked the first time a human being stood on a world other than planet Earth.

5

The desire to go to space is as old as humanity. Although the Sun and Moon were often characterised as gods by ancient civilisations, others saw them as places we might dream of visiting.

Many writers used their imagination to step off the Earth, usually in order to reflect humorously on its inhabitants. Improbable narratives of trips to the Moon include ‘True 10 History’ by Lucian of Samosata (second century), and Edgar Allan Poe’s ‘The Unparalleled Adventure of One Hans Pfaall’ (1835).

Despite fictional excitement, many longed to learn the truth. By the start of the twentieth century, technology was catching up with literary imagination, and a trip to the Moon was no longer just a flight of fancy.

15

However, since the last lunar landing in 1972, no missions beyond a low Earth orbit have included human life on board. In 1977, the Voyager probes<sup>1</sup> were sent on exploration past the planets of the solar system and out into deep space. More recently, robotic probes have landed on Mars, and even on a comet at the end of 2014. Humans, however, have been all but grounded.

20

Space flight is prohibitively expensive. A round trip to Mars would cost billions of dollars and require humans to spend at least eight months in space, probably a lot longer, depending on what technology was available. Although NASA has provisional plans to begin safe human missions to Mars in the mid-2030s, human space travel may depend on private enterprise rather than government cash.

25

Whether by public or private means, it seems the will is there for humans to have more than just a second-hand understanding of life on Mars. It is a daunting challenge, but so was flying to the Moon in 1969. And how motivational it is too that a human footstep on another world may well become the defining moment of the twenty-first century.

<sup>1</sup>probes – spacecrafts with no humans on board

Read **Text B**, and then answer **Question 1(f)** on the question paper.

### **Text B: The human swan**

*The British conservationist and 'human swan', Sacha Dench, travelled in a motorised paraglider (a paramotor) as part of a 7000 km journey. She was following migrating Bewick's swans from Russia to Britain in order to better understand the reasons for their declining numbers.*

'The whole way I've been trying to put myself in the head of a swan. There are times when I wish I was a swan. It would've been so much easier,' reflected Dench. 'When the temperatures got really cold I wished I could flap my arms and generate some heat, but that would make the whole paramotor shake.'

5

With her swan's-eye view of the world, Dench said she particularly appreciated crossing the Taiga forest of Russia, seeing no trace of human habitation, and witnessing the scale of the tundra. 'The colours of the tundra are the most beautiful I've ever seen in a landscape. They look as if they could be from Mars,' she said.

When she reached urbanisation, she met Russian schoolchildren who were sent out to shoot migrating birds for food. They were 'riveted by how conservation and research

10

works. They had no idea where the swans went.'

Although she took care to avoid disturbing other migrating birds, there were moments when they joined her. When she flew up to 900 metres above the clouds, the sky was filled with geese. 'You really felt in the thick of migration,' she said.

15

At one point, two white-fronted geese veered towards her. 'I was just about to turn away thinking there would be a collision when they suddenly flew alongside my wing-tips in a V-formation. That was very special,' she said.

On another occasion she flew 50 metres below a migrating flock of Bewick's swans. 'They drew right alongside me. I didn't look like a threat to them. I was just a big flying thing and they completely ignored me,' she said.

20

Low points included time spent in a Russian hospital for an MRI scan following a dislocated knee during a take-off. She also lost track of one of the satellite-tagged swans she was following, during foul weather in Estonia. Dench realized it had perished. 'You get quite attached to them as individuals,' she said.

Although flying low over the Taiga forest was particularly hazardous with its lack of safe

25

landing spots, crossing the English Channel was Dench's toughest challenge. 'When I crossed from Belgium into France and first saw the white cliffs of Dover I started to cry,' she said. 'I'm not much of a softy but I thought, actually, I am keen to be home.'



Read **Text C**, and then answer **Questions 2(a)–2(d)** and **Question 3** on the question

paper. **Text C: An incredible journey**

*In 1935, two men, Max (the narrator) and Helmuth, try to find a land route from India to China. Here, Max describes part of their journey from the Judaeen Desert in the Middle East and across the River Jordan.*

We set off on our desert journey the following day in good spirits, and full of high expectations. The car glided through the gorges of Judaea over bubbling hot asphalt until a sign-board in Arabic, Hebrew and English proclaimed the words 'Sea Level'. The way descended another 400 metres and it was a peculiar feeling to know that all the water in all the oceans of the world was towering above you like mountains. 5

In front of us lay the leaden expanse of the Dead Sea. Was it true that it was impossible to sink in it? I tried for myself while Helmuth looked on and smiled. You lie on top of the water, motionless, like a cork. Swimming in the conventional sense is not possible, since hands and feet flail around in the air like useless paddles. According to the brochures, one could 'read a newspaper undisturbed or hold up a sunshade'. A local photographer lurked nearby. 10

However, reading a newspaper in comfort is just a publicity stunt. After only a few minutes the salt begins to affect you. You itch and burn in every pore and I wanted nothing else than to get into the River Jordan double-quick and rinse the salt crust off. Helmuth laughed as I urged him to put his foot down on the accelerator. 15

We crossed the Jordan by bridge. This was where Asia really began.

The track leading up out of the Dead Sea depression, along the slopes of the Jordan valley, was stony and steep. We had to get over a high point of 1200 metres in the mountains. The May sun blazed fiercely and the engine laboured its way up in first gear. The radiator thermometer was already showing over 90 degrees. 20

'This car is far too heavy,' I eventually admitted.

Helmuth nodded silently. 'I did warn you, Max.'

Out of the corner of my eye I could see anxiety in his face, and I bit my lip controlling an urge to point out that most of our luggage was his, packed lovingly by his mother before we started out. The overloaded car springs were groaning on the bumpy road. 25

100 degrees. The radiator boiled and whistled. I stopped the car. Helmuth dug out our map of Asia. 'Here's Palestine and there's China,' he said. 'We've come about 400 km so far, and there are about 23 000 still to go.'

We sat there for a long time brooding, side by side, with the big map of Asia on our knees. We were both depressed but understood the need not to let this turn into recrimination. 30

Our weight was at the root of our whole problem. 'We'll have to downsize,' I said. 'We'll have to jettison some of our luggage.'

Helmuth nodded silently, staring at the boxes in the rear of the car.

'Maybe we can manage with them as far as Baghdad,' I offered, 'and they can be put into

Easier in our minds, we waited for darkness to fall before we drove on. Night journeys are not only cooler but are beautiful in the East. Over the landscape arched a sky sparkling with a plethora of stars. Along the rocks of the gorge huddled flocks of storks,

40

shining like patches of snow as the light danced on their plumage. I wished I'd brought a better camera. The birds were not alarmed, being tired from their long journey. They had come from the Sudan, and the next day they would fly on to their northern kingdom and the European springtime. A few of them raised their heads sleepily from their feathers and followed us with the long, serious gaze of philosophers. Perhaps they were thinking, 'Funny these humans going south just now.'

At eleven o'clock we gratefully pitched camp. Sleeping on camp beds in the open with the gentle warm breezes caressing our faces was wonderful. 45

KOTHARI INTERNATIONAL SCHOOL, NOIDA

CAMBRIDGE ASSESSMENT INTERNATIONAL EDUCATION SESSION 2021-22  
IGCSE LEVEL 2 MOCK TEST PAPER 1 QP

Dear Students please attempt this paper and time it.

**SUBJECT:** ENGLISH    **Max Marks:** 80    **TIME ALLOTTED:** 2 hours

You will need: Insert (enclosed)

**INSTRUCTIONS**

- Answer **all** questions.
- Use a black or dark blue pen.
- Write your name, centre number and candidate number in the boxes at the top of the page.
- Write your answer to each question in the space provided.
- Do **not** use an erasable pen or correction fluid.
- Do **not** write on any bar codes.
- If additional space is needed, you should use the lined pages at the end of this booklet; the question number or numbers must be clearly shown.
- Dictionaries are **not** allowed.

**INFORMATION**

- The total mark for this paper is 80.
- The number of marks for each question or part question is shown in brackets [ ].
- The insert contains the reading texts.

Read **Text A, *Space travel***, in the insert and then answer **Questions 1(a)-(e)** on this question paper.

**Question 1**

(a)

Give **two** examples of the ways in which the Sun and Moon have been viewed, according to paragraph 2.

• .....

• ..... [1]

(b) Using your own words, explain what the text means by:

(i) 'reflect humorously' (lines 8–9):

.....  
..... [2]

(ii) 'Improbable narratives' (line 9):

.....  
..... [2]

(c) Re-read paragraph 4 ('Despite fictional excitement a flight of fancy.').

Give **two** reasons why space travel became more likely in the twentieth century.

- .....
- ..... [2]

(d) Re-read paragraphs 5 and 6 ('However, since government cash.').

(i) Identify **two** reasons why probes have been an advantage to space exploration.

- .....
- ..... [2]

(ii) Explain why humans have not so far been to Mars.

.....  
.....  
..... [3]

(e) Re-read paragraph 7 ('Whether by public twenty-first century.').

**Using your own words**, explain why there is a good chance that humans will land on Mars in the twenty-first century.

.....  
.....  
..... [3]

Read **Text B, *The human swan***, in the insert and then answer **Question 1(f)** on this question paper.

**Question 1**

(f) According to Text B, what were the challenges that Sacha Dench experienced during her journey? You must **use continuous writing** (not note form) and **use your own words** as far as possible. Your summary should not be more than 120 words.

**Up to 10 marks are available for the content of your answer and up to 5 marks for the quality of your writing.**

.....  
.....

Read **Text C, *An incredible journey***, in the insert and then answer **Questions 2(a)–(d)** on this question paper.

**Question 2 Identify a word or phrase from the text** which suggests the same idea as the words underlined:

(A) (i) Max and Helmuth had great hopes for their journey.

..... [1]

(ii) The sun was very hot and strong.

..... [1]

(iii) The radiator overheated and made a high-pitched noise.

..... [1]

(iv) Max and Helmuth were buried in deep and unhappy thoughts.

..... [1]

(b) **Using your own words**, explain what the writer means by each of the words underlined:

Our weight was at the root of our whole problem. ‘We’ll have to downsize,’ I said. ‘We’ll have to jettison some of our luggage.’

(i) root ..... [1]

(ii) whole ..... [1]

(iii) jettison ..... [1]

(c)

Use **one** example from the text below to explain how the writer suggests the feelings of the men about camping out in the open on this particular night.

**Use your own words in your explanation.**

At eleven o'clock we gratefully pitched camp. Sleeping on camp beds in the open with the gentle warm breezes caressing our faces was wonderful.

.....  
.....  
..... [3]

(d) Re-read paragraphs 2 and 14.

- Paragraph 2 begins 'In front of us lay ' and is about Max's expectations and experience in the Dead Sea.
- Paragraph 14 begins 'Easier in our minds ' and is about what Max and Helmuth see while driving in the evening.

Explain how the writer uses language to convey meaning and to create effect in these paragraphs. Choose **three** examples of words or phrases from **each** paragraph to support your answer. Your choices should include the use of imagery.

**Write about 200 to 300 words.**

**Up to 15 marks are available for the content of your answer.**

.....  
.....  
.....

Re-read **Text C, *An incredible journey***, in the insert and then answer **Question 3** on this question paper.

**Question 3**

Imagine you are Helmuth from **Text C**. Straight after the evening that you and Max pitch camp, you

write a letter to your mother.

In your letter you should comment on:

- the most enjoyable parts of your journey so far **and** why they were enjoyable
- the challenges you and Max faced **and** how you overcame these challenges
- the problems you foresee for the rest of the trip **and** how you might have been better prepared for them.

**Write the words of your letter.**

Base your letter on what you have read in **Text C**, but be careful to use your own words. Address each of the three bullets.

Write about 250 to 350 words.

**Up to 15 marks are available for the content of your answer and up to 10 marks for the quality of your writing.**

.....

**SUBJECT:**

Physics

**Time to be Spent**

**(One Hours per day for 10 Days) :**

10 hours

**Work  
Specification :**

**Project Work:**

1. Solve the worksheet given in holiday homework.
2. Do the research work on the topic given below;

The purpose of this research work is to let student explore different areas of application of various phenomena of physics they studied and will be studying ahead under topic **electricity**. The research-based work will help them evaluating and observing the various factors related to electricity.

Students are required to keep a note of following as well:

1. Presentation (PPT)
2. Project file (Report file)

The project file should include;

- **CONTENTS** (All topics and sub topics)  
↓  
1 page
- **ACKNOWLEDGEMENT** (People who have helped/inspired you for this project)  
↓  
1 page
- **INTRODUCTION** (Brief outline of the topic given)  
↓  
1 page
- **OBJECTIVE AND SCOPE**  
↓  
1 to 2 pages



	<ul style="list-style-type: none"> <li>• <b><u>METHODOLOGY AND MAIN BODY</u></b> ↓ 5 to 8 pages</li> <li>• <b><u>BIBLIOGRAPHY</u></b></li> </ul>
--	--

<b>Materials Required:</b>	<ol style="list-style-type: none"> <li>1. Workbook, Home Work Notebook</li> <li>2. Internet,</li> <li>3. Details of all electrical appliances at home including bulbs, fans, A.C. e.t.c.</li> <li>4. Electricity bills of month April and May</li> </ol>
----------------------------	--

<b>Instructions / Guidelines:</b>	<p>Each student is supposed to perform this separately. <b>NO GROUP WORK ALLOWED.</b></p> <p><b>Topic: Observing &amp; evaluating power consumption in the month of April and May of various appliances at home.</b></p> <p><u>Steps:</u></p> <ol style="list-style-type: none"> <li>1. Collect data of power rating and number of appliances at home.</li> <li>2. Make a chart and enlist each appliance and its duration of operation.</li> <li>3. Calculate the power consumption based on the formula under topic electricity. (refer text book, internet)</li> <li>4. Once individual power consumption is calculated, get the summation of all the appliances.</li> <li>5. Check the cost for consuming 1 unit of electrical energy.</li> <li>6. Calculate for total number of appliances used in month in April and May.</li> <li>7. Compare the calculated amount with your electricity bill and observe the difference and enlist the appliances you haven't considered while going through with your</li> </ol>
-----------------------------------	---

	<p>analysis.</p> <ol style="list-style-type: none"><li>8. Paste the copy of electricity bills to support your project work and analysis.</li><li>9. Spiral bind file with school logo and Cambridge logo on its front page, mentioning you details and topic of the project work.</li><li>10. Prepare a presentation for the same. Mail the presentation</li></ol>
--	--

# Holiday Homework

## Physics IGCSE

Q.1. The top graph shows the distance/time graph for a girl's bicycle ride and the bottom graph gives the axes for the corresponding speed/time graph.

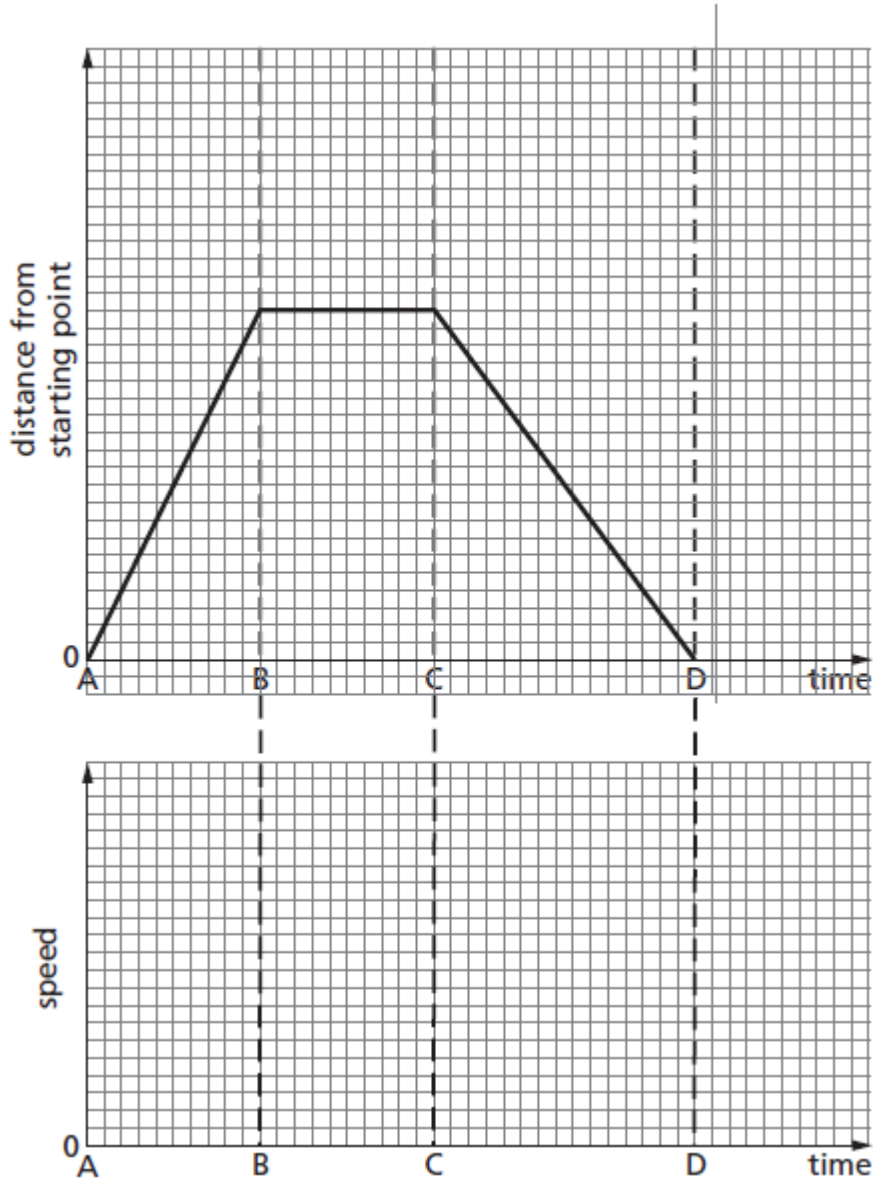

- a) Look at the distance/time graph that has been drawn for you.
  - (i) Answer the following questions for the time interval AB.
    - 1 What is happening to the distance from the starting point?
    - 2 What can you say about the speed of the bicycle?
  - (ii) On a copy of the speed/time axes on the bottom graph, draw a thick line that could show the speed during AB.
- b) On your copy of the speed/time axes
  - (i) draw a thick line that could show the speed during BC,
  - (ii) draw a thick line that could show the speed during CD.
- c) How far from her starting point is the girl when she has finished her ride?

Q.2. A car of mass 900 kg is travelling at a steady speed of 30 m/s against a resistive force of 2000 N, as illustrated in the diagram.

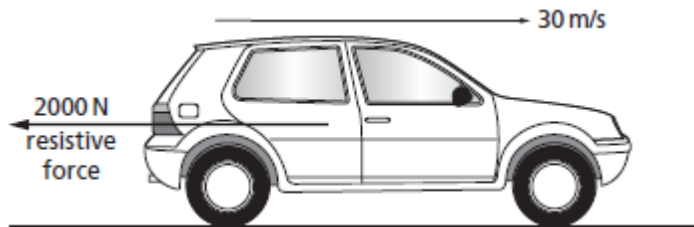

- a) Calculate the kinetic energy of the car.
- b) Calculate the energy used in 1.0 s against the resistive force.
- c) What is the minimum power that the car engine has to deliver to the wheels?
- d) What form of energy is in the fuel, used by the engine to drive the car?
- e) State why the energy in the fuel is converted at a greater rate than you have calculated in c.

Q.3. Complete the sentences. Choose from the words in the box.

solid                  liquid                  gas

The words may be used once, more than once or not at all.

- a) The atoms are usually arranged in regular patterns in a .....
- b) The state of matter with the lowest density is a .....
- c) Evaporation takes place when the most energetic molecules leave the surface of a .....
- d) A small force can change the volume of a .....

Q.4. In a training session, a racing cyclist's journey is in three stages.

Stage 1 He accelerates uniformly from rest to 12 m/s in 20 s.

Stage 2 He cycles at 12 m/s for a distance of 4800 m.

Stage 3 He decelerates uniformly to rest.

The whole journey takes 500 s.

- a) Calculate the time taken for stage 2.

b) On a copy of the grid below, draw a speed/time graph of the cyclist's ride.

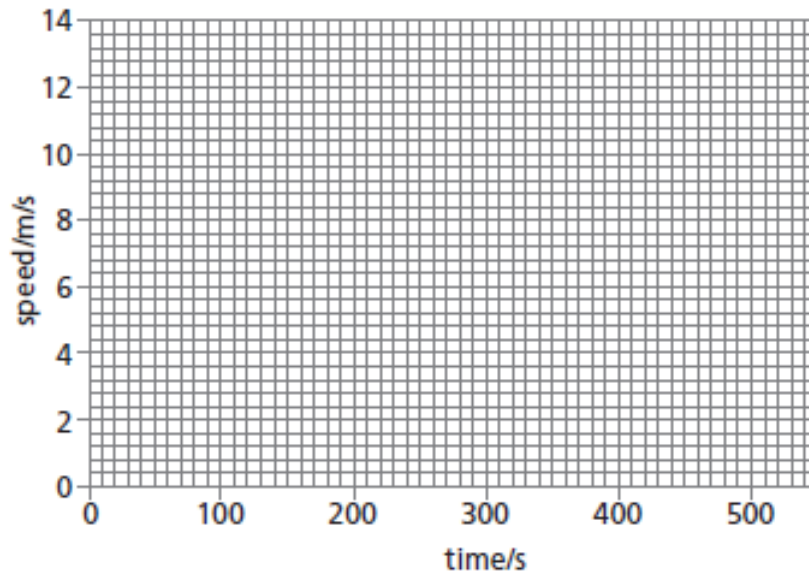

- c) Show that the total distance travelled by the cyclist is 5400 m.
- d) Calculate the average speed of the cyclist.

Q.5. A 250 cm<sup>3</sup> beaker containing some liquid is shown in Figure given below.

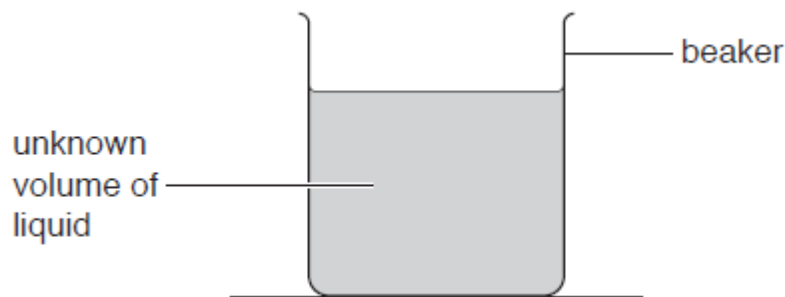

- a) (i) A student has a measuring cylinder and a balance. Describe an experiment to determine the density of the liquid.
- (ii) Suggest the unit of density used by the student.
- b) Figure below shows a block of polythene.

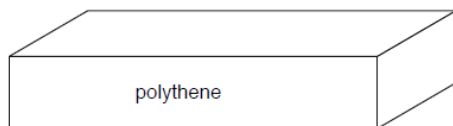

- (i) Polythene floats in water. Explain why polythene floats.
- (ii) The weight of the polythene block is 0.84 N. Calculate the mass of the block.

Q.6. Multiple choice questions.

- I. Which of the following physical quantities is not a base quantity?
- A. Weight
  - B. Temperature
  - C. Time
  - D. Electric current<sup>2</sup>.

- II. Which physical quantity has the correct SI unit?

	Physical quantity	S.I. unit
A	Temperature	celcius
B	Time	minute
C	Weight	kilogram
D	Length	metre

- III. Which of the following frequencies is same as 106.8 MHz?

- A.  $1.068 \times 10^{-4}$  Hz
- B.  $1.068 \times 10^2$  Hz
- C.  $1.068 \times 10^6$  Hz
- D.  $1.068 \times 10^8$  Hz

- IV. Density can be calculated from the expression

- A mass/volume
- B mass  $\times$  volume
- C volume/mass
- D weight/area
- E area  $\times$  weight

- V. Which are the basic SI units of mass, length and time?

- A kilogram, kilometre, second
- B gram, centimetre, minute
- C kilogram, centimetre, second
- D gram, centimetre, second
- E kilogram, metre, second

- VI. Which of the following properties are the same for an object on Earth and on the Moon?

1 weight    2 mass    3 density

Use the answer code:

- A 1, 2, 3    B 1, 2    C 2, 3    D 1    E 3

Q.7. An engineering machine has a piston which is going up and down approximately 75 times per minute. Describe carefully how a stopwatch may be used to find accurately the time for one up-and-down cycle of the piston.

Q.8. a (i) The two diagrams show the dimensions of a rectangular block being measured using a ruler. They are not shown full size. Use the scales shown to find the length and the width of the block, giving your answers in cm.

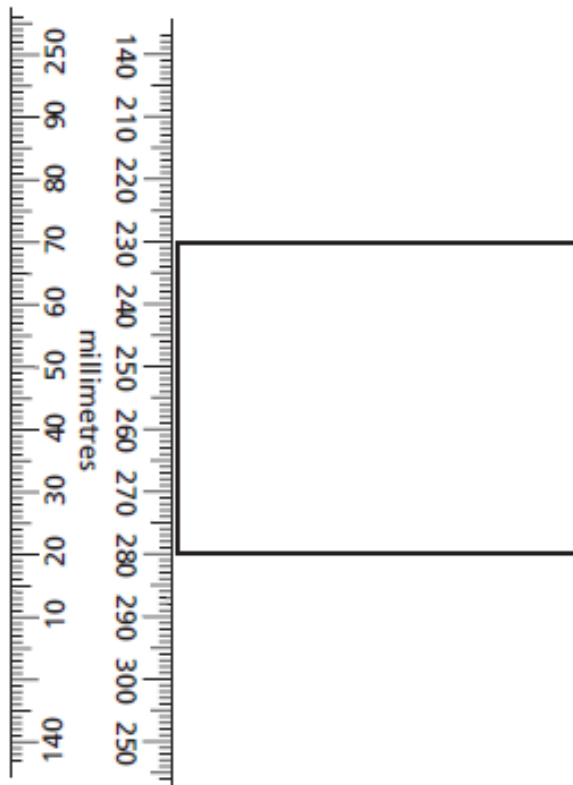
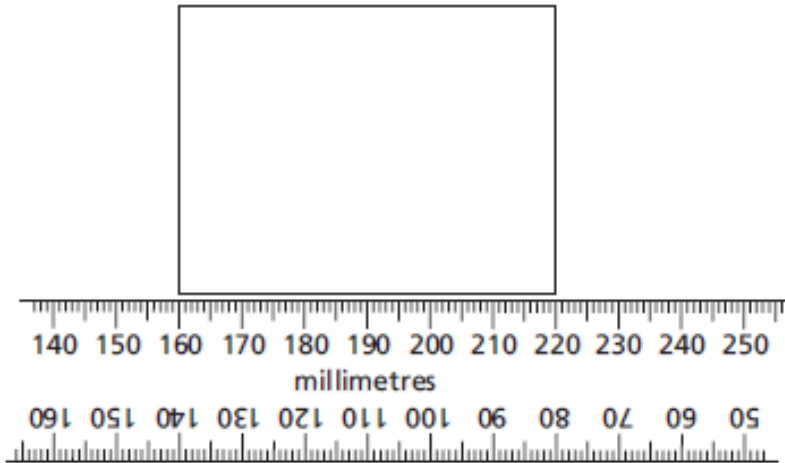

(ii) When the block was made, it was cut from a piece of metal 2.0 cm thick. Calculate the volume of the block.

b Another block has a volume of  $20 \text{ cm}^3$ . The diagram shows the reading when the block is placed on a balance.

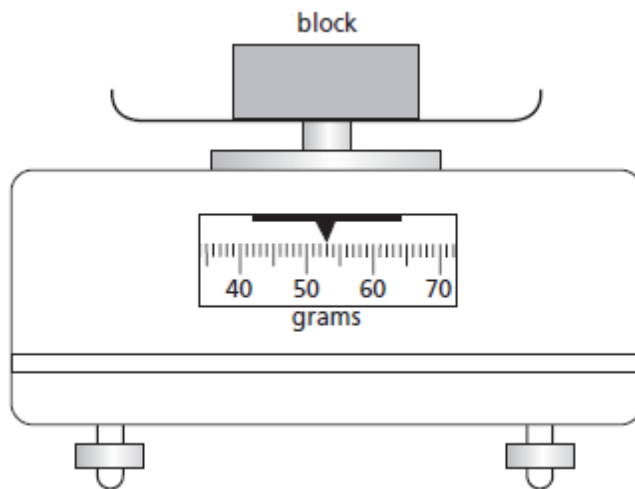

Q.9. A student clamps a metre rule to the end of a bench, as shown in Fig. 1.1. He attaches a mass to the end of the rule.

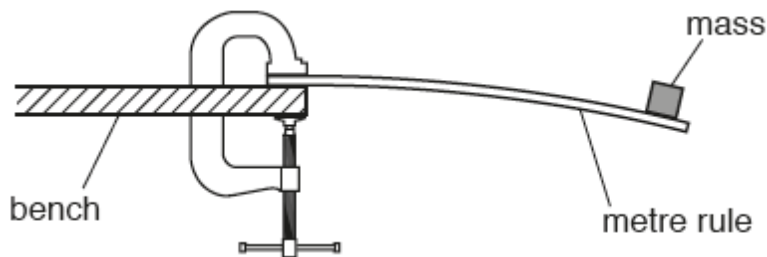

The student displaces the end of the rule by a small distance. The rule oscillates up and down.

The student measures the time for ten complete oscillations.

- State the name of a measuring device for timing the oscillations.
- State a reason why the student measures the time for ten oscillations, rather than for one.
- The student repeats the procedure. His results are shown in the table.



results	time for ten complete oscillations/seconds
1st	3.93
2nd	4.07
3rd	3.55
4th	3.99

- (i) One of the results is incorrect. On the table, draw a ring around the incorrect result.
- (ii) Calculate the average value for the time for ten complete oscillations.
- (iii) Determine the time for one complete oscillation.

Kothari International School  
Summer BREAK- Holiday Assignment  
Session - 2023-24  
Cambridge IGCSE-2

Q.1. The markets for cars and tyres are closely related. The five largest tyre firms used to make 66% of all tyres. The entry of more than 250 Chinese firms has reduced the global market share of the largest five firms to less than 50%. This also changed the price elasticity of demand (PED) for individual firms' tyres. Some of these firms are state-owned enterprises and some are in the private sector.

- (a) Identify two types of business organisation that operate in the private sector.
- (b) Explain what effect more firms producing tyres would have on the PED of individual firms' tyres.
- (c) Analyse, using a demand and supply diagram, the effect of an increase in demand for cars on the market for tyres.
- (d) Discuss whether a large firm will earn more profit per unit sold than a small firm.

Q.2. In March 2017, Peru was hit by floods and the strongest winds in decades. Roads, bridges, houses and capital goods were destroyed. It is expected that the damage caused will affect Peru's Human Development Index (HDI) and economic growth rate. In 2016, Peru experienced a 4% economic growth rate which was higher than the growth rate of the USA.

- (a) Define a capital good.
- (b) Explain two causes of an increase in a country's HDI.
- (c) Analyse, using a production possibility curve (PPC) diagram, the effect of damaging weather on an economy.
- (d) Discuss whether countries with a high Gross Domestic Product (GDP) per head will have a faster rate of economic growth than countries with a low GDP per head

# KOTHARI INTERNATIONAL SCHOOL, NOIDA

## IGCSE-2 ACCOUNTING ASSIGNMENT – HOLIDAY HOME WORK

Q1.

Krishna has a secretarial agency. Her financial year ends on 30 April.

She provided the following information for the year ended 30 April 2019.

	\$
Fees received from clients	35 270
Wages	24 300
Operating expenses	4 260
Rent and rates	7 750
Motor expenses	720
Commission receivable	1 820
Office fixtures and equipment at valuation 1 May 2018	18 900
Motor vehicle at cost	17 500
Provision for depreciation of motor vehicle	6 300

Additional information

- At 30 April 2019  
Clients owed fees totalling \$2150.  
Commission receivable accrued amounted to \$60.  
Rent, \$1200, was accrued.  
Rates prepaid amounted to \$550.
- Krishna lives in an apartment above the business premises. One quarter of the rent and rates relates to Krishna's apartment.
- The office fixtures and equipment were valued at \$17 320 on 30 April 2019.  
No office fixtures and equipment were purchased or sold during the year.
- The motor vehicle is to be depreciated at 20% per annum using the reducing (diminishing) balance method.

### REQUIRED

- (a) Prepare Krishna's income statement for the year ended 30 April 2019.

Krishna  
Income Statement for the year ended 30 April 2019

- (b) Complete the following accounts in Krishna's ledger for the year ended 30 April 2019.  
Close the accounts by balancing or by making an appropriate year-end transfer.

[13]

Krishna  
Drawings account

Date	Details	\$	Date	Details	\$
2019 April 30	Total cash drawings	9 150	.....	.....	.....
.....	.....	.....	.....	.....	.....
.....	.....	.....	.....	.....	.....
.....	.....	.....	.....	.....	.....
.....	.....	.....	.....	.....	.....

Capital account

Date	Details	\$	Date	Details	\$
.....	.....	.....	2018 May 1	Balance b/d	38 000
.....	.....	.....	.....	.....	.....
.....	.....	.....	.....	.....	.....
.....	.....	.....	.....	.....	.....
.....	.....	.....	.....	.....	.....

[5]

**Q2** The financial year of the KS Sports Club ends on 31 July. The club has 150 members and the annual subscription is \$50.

On 1 August 2018 subscriptions were outstanding from 5 members and 2 members had paid their subscription in advance for the next financial year.

On 31 July 2019 subscriptions had been paid in advance for the next financial year by 4 members.

**REQUIRED**

- (a) Prepare the subscriptions account for the year ended 31 July 2019 to show the amount received for subscriptions during the year.  
Balance the account and bring down the balance on 1 August 2019.

[6]

The treasurer of the KS Sports Club provided the following information.

	\$
At 1 August 2018	
Bank overdraft	2620
5% loan from AB Loans	2000

Receipts and payments during the year ended 31 July 2019

Subscriptions received from members	?
Loan interest and repayment of loan	2100
Short-term interest-free loan received from a member	1000
General expenses	435
Rates and insurance	3120
Purchase of new sports equipment	4150
Repairs to sports equipment	215
Proceeds of sale of old sports equipment (book value \$750)	870
Receipts from sports tournament	525
Expenses of sports tournament	335

At 31 July 2019

General expenses accrued	25
Insurance prepaid	150

- (b)** Prepare the receipts and payments account for the year ended 31 July 2019.  
Balance the account and bring down the balance on 1 August 2019.

Q3

Karishma runs her own business. The balances in her books on 1 October 2020 included the following.

	\$
Insurance account	1700 prepaid
Electricity account	1800 owing

During the financial year ended 30 September 2021 Karishma made the following payments by cheque.

Insurance payments	
	\$
7 February 2021	3400
13 August 2021	3500

Electricity payments	
	\$
14 October 2020	1800
24 January 2021	1800
26 May 2021	1800

A refund of \$300 for insurance overpaid was received by bank transfer on 28 February 2021. The insurance paid on 13 August 2021 covered a period of five months to 31 December 2021.

At 30 September 2021, an amount of \$2000 was owing for electricity.

- (a) Prepare the following accounts for the year ended 30 September 2021. Balance the accounts and bring down the balances on 1 October 2021.

Karishma  
Insurance account

Electricity account

**REQUIRED**

- (b) Advise Karishma whether she should change to the new electricity supplier. Justify your answer with **two** advantages and **two** disadvantages of changing supplier.

[10]

[5]

Q4

Simon has a business selling office stationery. On 1 January 2019 he owned two delivery vehicles which had been purchased on 1 January 2018.

Delivery vehicle A had cost \$30000 and delivery vehicle B had cost \$25000.

Simon uses the straight-line method for depreciating the delivery vehicles. A rate of 20% per annum on cost is used, with the rate being applied for each part of the year for which the delivery vehicles are owned.

Due to a decline in business, delivery vehicle B was sold on 31 March 2020 and a cheque for \$10350 was received. Delivery vehicle A was still in use at the end of 2020.







Delivery vehicles disposal account

Date	Details	\$	Date	Details	\$
.....	.....	.....	.....	.....	.....
.....	.....	.....	.....	.....	.....
.....	.....	.....	.....	.....	.....
.....	.....	.....	.....	.....	.....
.....	.....	.....	.....	.....	.....
.....	.....	.....	.....	.....	.....
.....	.....	.....	.....	.....	.....
.....	.....	.....	.....	.....	.....

Simon's sister Yasmin is also in business and depreciates her delivery vehicles by the reducing balance method.

Simon is considering whether to apply the reducing balance method of depreciation to his delivery vehicles.

**REQUIRED**

(b) Advise Simon whether he should apply the reducing balance method of depreciation. Justify your answer.

[15]

[5]

Q5

Amira, a sole trader, does not keep full accounting records. She has provided the following information.

	1 April 2020 \$	31 March 2021 \$
Motor vehicle Cost	40 000	50 000
Accumulated depreciation	19 520	<b>To be calculated</b>
Land	31 670	31 670
Cash at bank	1 350	1 650 Cr
Inventory	21 500	24 000
Other receivables - insurance	1 500	-
Trade payables	32 000	31 000
Trade receivables	34 500	37 500

During the year ended 31 March 2021 Amira sold her motor vehicle for \$22 940.

In addition, she purchased a new motor vehicle costing \$50 000. Motor vehicles are depreciated at 20% per annum using the reducing balance method. A full year's depreciation is charged in the year of purchase and none in the year of disposal.

Amira borrowed \$50 000 as an interest free loan repayable in five equal annual instalments. The first instalment was paid on 31 March 2021.

Her cash drawings during the year amounted to \$25 000 and she also took goods costing \$5 000 for her personal use.

At 31 March 2021 irrecoverable debts of \$2 500 were to be written off. A provision for irrecoverable debts of 5% was to be created.

(a) Prepare the statement of affairs (statement of financial position) at 1 April 2020.

(b) Prepare the statement of affairs (statement of financial position) at 31 March 2021.

[4]

[11]

**KOTHARI INETRINATION SCHOOL, NOIDA**  
**FRENCH ASSIGNMENT**  
**IGCSE 2**

Section 1

**Exercice 1 Questions 1–5**

Répondez aux questions en cochant la bonne case.

1 Vous lisez :

*Mon père est infirmier.*

Que fait le père ?

A	<input type="checkbox"/>
B	<input type="checkbox"/>
C	<input type="checkbox"/>
D	<input type="checkbox"/>

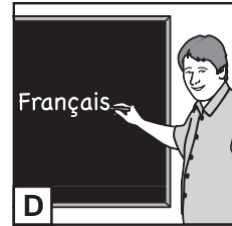
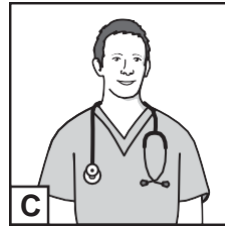
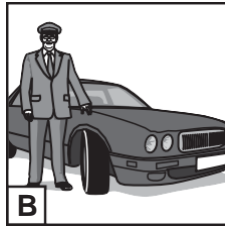
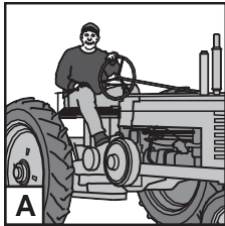

[1]

2 Un ami vous laisse un message :

*Demain nous allons faire une randonnée.*

Qu'est-ce qu'on va faire ?

A	<input type="checkbox"/>
B	<input type="checkbox"/>
C	<input type="checkbox"/>
D	<input type="checkbox"/>

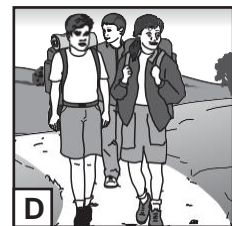
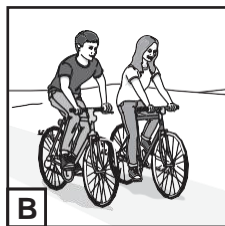
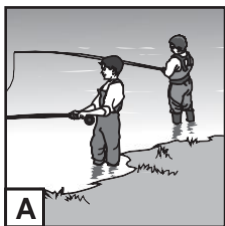

[1]

3 En ville, vous voulez parler à un agent de police.

Où allez-vous ?

A	
B	
C	
D	

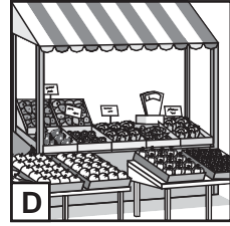
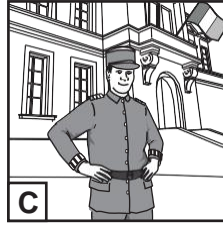
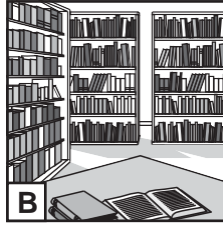
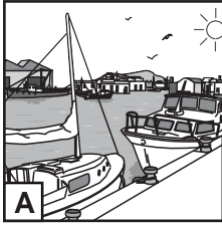

[1]

4 Vous recevez une invitation.

*Venez cet après-midi à seize heures quarante-cinq.*

C'est pour quelle heure ?

A	
B	
C	
D	

16:30

16:45

17:15

17:45

[1]

5 Vous lisez un message :

*N'oubliez pas d'acheter un timbre.*

A	
B	
C	
D	

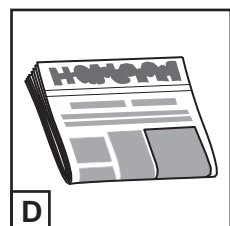
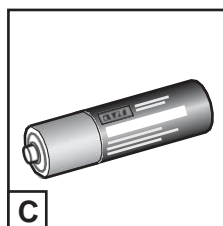
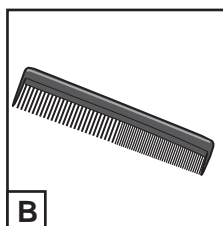
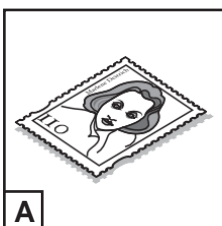

[1]

[Total : 5]

## Exercice 2 Questions 6–10

Regardez les images.

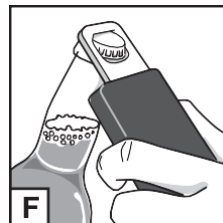
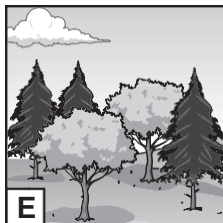
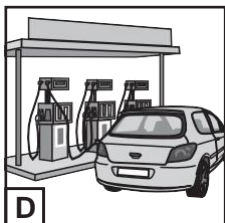
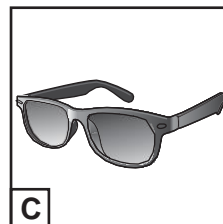
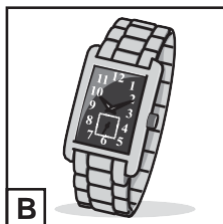
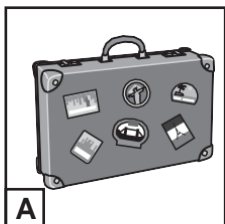

Écrivez la bonne lettre (A, B, C, D, E ou F) dans la case appropriée.

6 Armand travaille à la station-service.

[1]

7 Jules regarde les arbres.

[1]

8 Léo porte des lunettes de soleil.

[1]

9 Arthur part en vacances. Il fait sa valise.

[1]

10 Tom cherche un ouvre-bouteille.

[1]

[Total : 5]

### Exercice 3 Questions 11–15

Lucie envoie un courriel à une amie. Lisez le texte attentivement.

Salut !

Je suis interne dans un collège privé. Ça veut dire que je suis au collège du lundi matin jusqu'au vendredi soir et que je passe tous les week-ends chez mes parents. Au collège, je me réveille à 7h dans ma chambre qui est un dortoir pour quatre filles. Après le petit déjeuner, les cours commencent à 8h05 et finissent à 16h30. C'est long, n'est-ce pas ?

Il y a des règlements assez stricts, mais ce qui est bien c'est que nous avons le droit d'utiliser un téléphone portable entre 18h et 20h.

Lucie

**Cochez la bonne case.**

11 L'école de Lucie a...

**A**  un stade.

**B**  un cinéma.

**C**  un internat.

[1]

12 Le vendredi soir, Lucie...

**A**  joue de la musique.

**B**  rentre chez elle.

**C**  revient au collège.

[1]

13 Au collège, Lucie est obligée de...

**A**  jouer au volley.

**B**  porter un uniforme.

**C**  partager une chambre.

[1]

14 Pour Lucie, la journée scolaire...

**A**  commence tard.

**B**  est ennuyeuse.

**C**  dure longtemps.

[1]

15 Lucie peut se servir de son portable...

**A**  tout le temps.

**B**  le soir seulement.

**C**  pendant la pause-déjeuner.

[1]

[Total : 5]

## Section 2

### Exercice 1 Questions 16–20

Lisez le texte.

### Club d'informatique

Notre club permet à tous les gens du village de partager leur expérience en informatique. On peut apprendre à mieux se servir de son ordinateur dans une ambiance agréable et les moins de 16 ans ne doivent rien payer.

On se retrouve tous les samedis entre 9h et 11h30 dans la salle des fêtes du village. Pendant les réunions, vous pouvez faire une présentation sur quelque chose qui vous intéresse, par exemple e-mail. Vous aurez aussi la possibilité de poser des questions, ce qui est très utile si vous avez des difficultés avec votre ordinateur ou portable.

Complétez les phrases avec un mot français choisi dans la grille.

adultes	après-midi	compétitions	demander
donner	jeunes	matin	réparer
réunions	utiliser		

- 16 Au club, on apprend à ..... son ordinateur. [1]
- 17 Ce club est gratuit pour les ..... [1]
- 18 On se réunit le samedi ..... [1]
- 19 Les membres peuvent participer activement aux ..... [1]
- 20 Si on a un problème avec la technologie on peut ..... de l'aide. [1]

[Total : 5]



**Tournez la page pour l'Exercice 2.**

## Exercice 2 Questions 21–30

Lucas envoie un courriel à un ami. Lisez-le, puis répondez aux questions **en français**.

Salut !

J'ai fêté mon quinzième anniversaire la semaine dernière. Cette année, mes parents m'ont donné la permission d'organiser une fête à la maison. Moi, je voulais inviter une vingtaine de copains mais papa a insisté pour que j'en invite moins. Il était difficile de choisir seulement quelques copains car j'ai beaucoup d'amis. J'ai décidé de faire un barbecue dans le jardin.

Le jour de la fête, mes parents sont allés passer l'après-midi en ville. Moi, j'ai promis d'être sage et j'ai tout préparé. J'ai allumé le barbecue, j'ai sorti des boissons et j'ai fait cuire des saucisses et des hamburgers.

Pendant l'après-midi, tous mes amis étaient de bonne humeur. On mangeait beaucoup, on buvait et on écoutait de la musique. Tout allait bien quand un groupe de jeunes garçons, qui n'avaient pas été invités, est entré dans le jardin. Il y avait au moins vingt personnes dans notre petit jardin.

Plus tard, Papa et Maman sont revenus. Ils n'ont pas été contents en voyant ce qui se passait. Papa a dit à tout le monde de partir. En tout cas, c'est sûr que mes parents ne me donneront pas la permission d'organiser une fête pour mon seizième anniversaire.

Lucas

- 21 Lucas, quel âge a-t-il maintenant ?  
.....[1]
- 22 Où est-ce que la fête a eu lieu ?  
.....[1]
- 23 Combien de copains est-ce que Lucas voulait inviter ?  
.....[1]
- 24 Pourquoi Lucas ne pouvait-il pas inviter plus d'amis ?  
.....[1]
- 25 Où étaient les parents de Lucas pendant l'après-midi de la fête ?  
.....[1]
- 26 Qu'est-ce que Lucas faisait cuire au barbecue ?  
.....[1]
- 27 Qui est arrivé à la fête sans invitation ?  
.....[1]
- 28 Quand est-ce que les parents de Lucas sont rentrés ?  
.....[1]
- 29 Qu'est-ce que le père de Lucas a fait ?  
.....[1]
- 30 Pourquoi est-ce que Lucas ne fêtera pas son anniversaire à la maison l'année prochaine ?  
.....[1]

[Total : 10]

### Section 3

#### Exercice 1 Questions 31–35

Lisez le texte suivant, puis répondez aux questions en cochant la case **VRAI** ou **FAUX**. **Si l'affirmation est FAUSSE, corrigez-la selon le texte.**

(Il y a 2 affirmations qui sont vraies et 3 affirmations qui sont fausses.)

## Protéger les vacances

La France est un des pays les plus connus pour le tourisme. Chaque année, plus de 70 millions de touristes choisissent de venir y passer leurs vacances. C'est donc la responsabilité du gouvernement de tout faire pour que les touristes passent de bonnes vacances. Pour cela, leur sécurité est essentielle.

Le gouvernement a donc décidé, l'an dernier, de créer l'Organisation Interministérielle des Vacances (OIV) pour protéger, le plus possible, les touristes en vacances. L'OIV réunit de nombreux professionnels qui sont employés tout l'été, du 15 juin au 15 septembre, pour que les touristes passent des vacances sans problèmes.

Vanessa, par exemple, est spécialiste de la nourriture. L'été dernier, elle devait donc visiter des centaines de restaurants pour contrôler les cuisines. Quand elle remarquait que des restaurants ne suivaient pas les règlements ou qu'ils étaient sales, ces restaurants devaient fermer.

Damien est ingénieur spécialiste de l'eau. Il a passé l'été à contrôler la qualité des eaux où les touristes vont se baigner : les lacs, la mer et les piscines. Damien devait interdire aux touristes de se baigner quand la qualité de l'eau n'était pas assez bonne.

Pierre, lui, est spécialiste de la protection contre le feu. En effet, les incendies sont nombreux en France l'été, surtout dans les forêts. Son travail était donc de surveiller les forêts à cheval. Il expliquait aussi aux randonneurs et aux campeurs comment éviter les incendies causés par les barbecues et les feux de camp.

L'OIV a donc été un succès car cette organisation a sans aucun doute sauvé la vie de nombreux touristes. Les ingénieurs spécialistes ont fait plus de 30 000 contrôles cet été. Le gouvernement vient de décider de refaire cette expérience l'année prochaine.

**Exemple :**

Peu de gens choisissent la France comme destination de vacances.

**VRAI****FAUX**

*Il y a plus de 70 millions de touristes en France chaque année.*

**VRAI****FAUX**

31 C'est à l'État français de s'occuper de la sécurité des touristes.

32 Vanessa devait conseiller aux touristes les meilleurs restaurants.

33 Les restaurants qui ne suivaient pas le règlement devaient payer une grosse somme d'argent.

34 Pierre organisait des randonnées en forêt pour des groupes de touristes.

35 Grâce à l'OIV, il y a maintenant moins de risques pour les vacanciers en France.

**VRAI****FAUX**

[Total : 8]

## Exercice 2 Questions 36–42

Lisez le texte suivant, puis répondez aux questions **en français**.

# L'Europe à vélo

Mathieu, 23 ans, avait un projet : traverser toute l'Union européenne à vélo. Pendant un séjour en Grèce, Mathieu avait rencontré beaucoup de jeunes européens et il avait réalisé qu'il ne connaissait pas très bien l'Europe.

À la fin de ses études, Mathieu est donc parti. Pour découvrir 28 pays européens, il a choisi le vélo, « *ce qui est super à vélo, c'est que ça me permet de rencontrer des gens* », dit-il.

Les préparatifs du voyage lui ont pris six mois. Après avoir choisi sa route, il a choisi avec soin le matériel nécessaire à la réussite de son voyage. D'abord, le plus important c'était d'avoir un vélo approprié aux longues distances. Puis, Mathieu s'est entraîné tous les jours physiquement pour pouvoir faire 80 km par jour à vélo.

En même temps, Mathieu a cherché de l'argent pour payer ce voyage : il a contacté des sponsors, mais sans succès.  
« *Heureusement que mon université a accepté de me donner l'argent nécessaire !* »

Mathieu voulait voir les pays de l'Union européenne mais, ce qui l'intéressait surtout, c'était de faire l'expérience de cultures différentes. « *Alors pour cela, le vélo, c'était idéal !* » dit-il. « *Sur mon vélo, avec presque 35 kg de matériel, les gens me remarquaient et ils venaient me parler.* »

En sept mois, Mathieu a parcouru 9000 km à vélo. Il est rentré ravi de son voyage. « *C'est la générosité des gens que j'ai rencontrés qui m'a le plus surpris* », raconte-t-il. Pour Mathieu, le meilleur souvenir de son voyage a été une soirée passée avec un homme pauvre : cet homme lui avait donné son lit pour qu'il passe une bonne nuit avant de reprendre sa route.

- 36** Qu'est-ce que Mathieu a compris quand il était en Grèce ?  
.....[1]
- 37** Pour quelle raison Mathieu a-t-il choisi de voyager à vélo ?  
.....[1]
- 38** Pour réussir son projet, de quoi Mathieu avait-il surtout besoin ?  
.....[1]
- 39** Comment Mathieu a-t-il payé son voyage ?  
.....[1]
- 40** Qu'est-ce que Mathieu était surtout curieux de découvrir dans les pays visités ?  
.....[1]
- 41** Pourquoi les gens remarquaient-ils Mathieu sur son vélo ?  
.....[1]
- 42** Quelle action généreuse Mathieu a-t-il le plus appréciée pendant son voyage ?  
.....[1]

[Total : 7]

**1. Mon emploi du temps scolaire**

- À quelle heure est-ce que l'école commence et finit ?
- Combien de cours y a-t-il par jour ?
- Décrivez ce que vous faites pendant la pause-déjeuner.
- Quelles matières est-ce que vous aimez/n'aimez pas ? Pourquoi ?
- Qu'est-ce que vous voudriez étudier l'année prochaine ?

Écrivez environ 80-90 mots **en français**.

.....

.....

.....

.....

.....

.....

.....

.....

.....

.....

.....

.....

.....

.....

.....

.....

.....

.....

.....

.....

.....

.....



**Tournez la page pour la Section  
2.**

## Section 2

### 2. Vous devez écrire 130–140 mots en français.

#### (a) Un week-end spécial

Vous avez passé un excellent week-end. Écrivez une lettre à un(e) ami(e) français(e).

- Qu'est-ce que vous avez fait pendant ce week-end spécial ?
- Expliquez pourquoi c'était excellent.
- Quelle est l'importance du week-end pour vous ?
- Que feriez-vous pour votre week-end idéal ? Donnez vos raisons.

ET

#### (b) La nouvelle voiture de mes parents

Vos parents ont acheté une nouvelle voiture. Écrivez un blog.

- Pourquoi vos parents ont-ils acheté une nouvelle voiture ?
- Décrivez votre première promenade dans cette voiture.
- Où voudriez-vous aller la prochaine fois que vous sortirez en voiture ?
- À votre avis, quels sont les avantages **et** les inconvénients de la voiture ?

ET

#### (c) Un barbecue désastreux

« Pour fêter la fin de l'année scolaire, mes ami(e)s et moi, nous avons fait un barbecue... »

### **Continuez l'histoire.**

- Décrivez ce barbecue (par exemple : où ? quand ? nourriture ?).
- Malheureusement, il y a eu un problème. Qu'est-ce qui s'est passé ?
- Quelle a été votre réaction ?
- Qu'est-ce que vos ami(e)s ont pensé de ce barbecue ?



# Additional Page

If you use the following lined page to complete the answer(s) to any question(s), the question number(s) must be clearly shown.

A series of horizontal dotted lines for writing answers.

